

Eight  
Complete  
Programs  
In this Issue

NO. 74

U.S. Edition  
International Edition

\$2.00  
\$3.50

AUGUST 1984

# MICRO

for the Serious Computerist

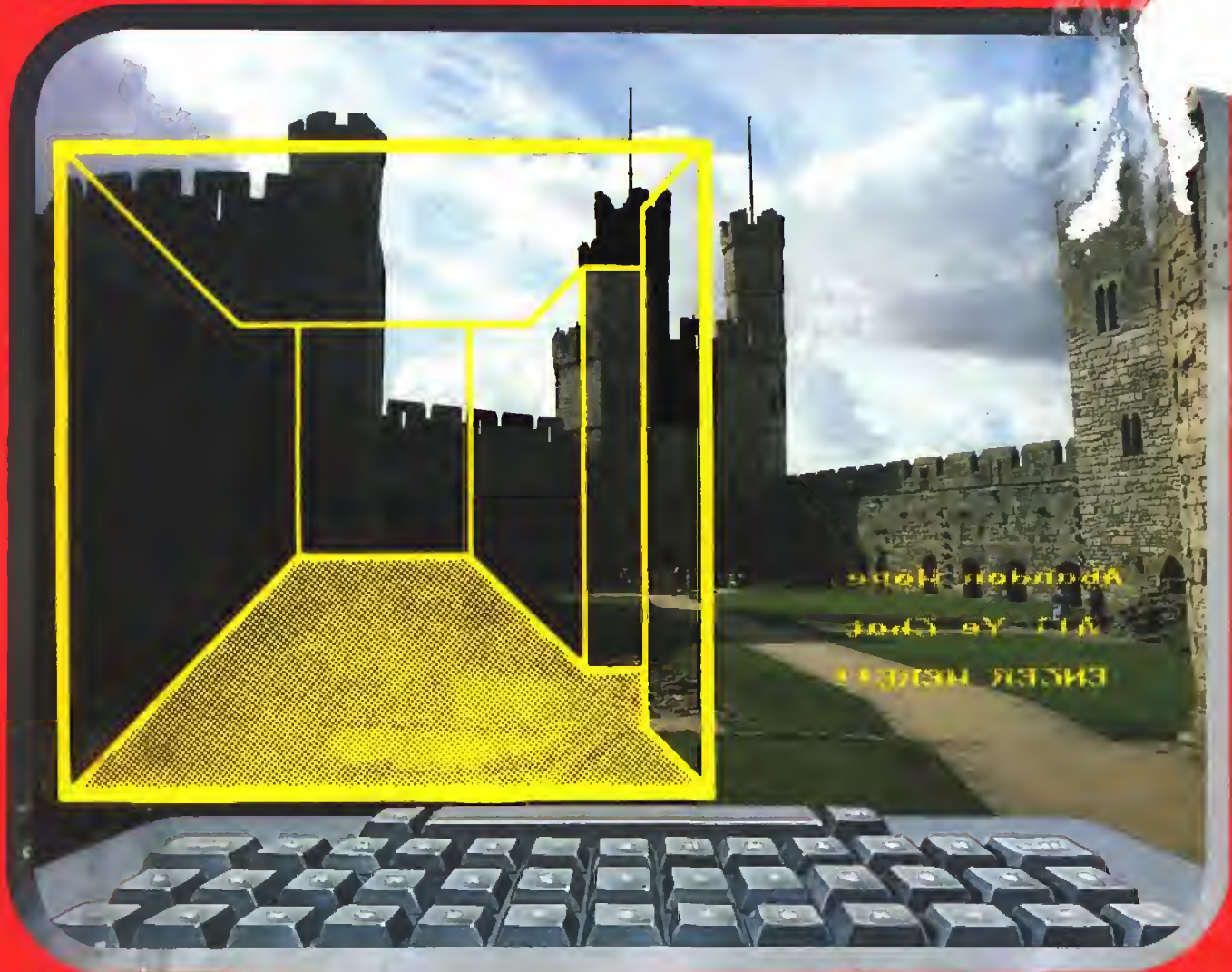

Useful Math Functions

3-D Mazes

Step/Trace Programs

HiRes Graphic Printouts

p-System Comparisons



# WARSHIP

NOW SHOWING

# BLITZ!<sup>TM</sup>

AT COMMODORE 64<sup>TM</sup> DEALERS

## The Fast BASIC Compiler

A stunning show delighted the crowd at the Whisman Theater in Mountain View last night. Called *BLITZ!*, loaded and performed by Robert Skyles in a one-man virtuoso programming display, the show features the spectacular compiler for the COMMODORE 64.

**"...BASIC programs running up to 20 times faster"**

The *BLITZ!* compiler is faster than PET SPEED, and faster than any other Commodore compiler that has appeared to date.

Shortly after Skyles took his seat and inserted *BLITZ!*, he had normal BASIC programs running up to 20 times faster after he *BLITZed* them.

The performer explained that *BLITZ!* translates the slow BASIC

language into a much faster code, thus improving the performance of the BASIC routines. *BLITZ!* reads the entire BASIC program, decides which operations only have to run once, and compiles the operations. It then re-writes the program into its special P-code.

Skyles also showed how *BLITZ!* adds security to your programs, because once a program has been compiled, it is not readable. That means protection is an automatic part of the re-writing.

The highlight of the show was, for this reviewer, when *BLITZ!* compiled a string of BASIC programs such that one loaded the next. An impressed audience looked on as Skyles effortlessly passed information from one program to another.

***BLITZ!* on disk for the Commodore 64 costs only \$99.00.**  
(You can also get one for the older PET CBMs on a special-order basis. It puts on quite a show!)



**Skyles Electric Works**

231E South Whisman Road  
Mountain View, CA 94041  
(415) 965-1735

Available from your local  
Commodore 64 dealer or  
call 1-800-227-9998.

*BLITZ!* is a trademark of Skyles Electric Works.  
Commodore is a trademark of Commodore.

# MORE THAN JUST THE TIP

Subscribe!  
to!

## The **Transactor**

The Tech/News Journal For Commodore Computers

### ...AND GET MORE FROM YOUR COMMODORE 64 AND VIC 20

"The Transactor is a constant resource."

JIM BUTTERFIELD

**CHECK THESE FEATURES:**

- Up-to-date: new products and services.
- Insights and strategies from respected expert Jim Butterfield.
- Interesting bits of news among Commodore users.

**SIMPLY THE BEST**

Subscribe now and you'll wonder how you got without it.

THE TRANSACTOR SUBSCRIPTIONS DEPT  
500 Steeles Avenue, Milton, ON L9T 3P7  
Telephone: **876-4741**

Year's subscription (6 issues) \$19.95  
Single issues \$2.75 each  
Back issues available.

## Sharing Information

I recently received a letter from a reader enquiring whether he could use one of our programs in a software package he was developing. As in any healthy field, a fair amount of cross-fertilization takes place within. This is particularly true in the world of software development where one great idea will spawn another.

Now in the midst of all of this comes that ancient cry of plagiarism. It is said that "mimicry is the sincerest form of flattery" but not all authors enjoy such attention. Where do you draw the line between what is plagiarism and what is a logical or original development of an idea? It seems more and more that this is a fine line — one that is made by the creator rather than the lawyer. Times are changing. There was a time when everyone 'borrowed' ideas from everyone else. Centuries ago in the music world this was common practice. But attitudes changed over the years to the point that people hoarded their ideas as their own and sued anyone who dared approach any similarity to their mental offspring. Now once again the tides are shifting in the other direction. This shift is putting many wonderful and original ideas in our hands. It is furthering new creations and saving a lot of wasted time in the process.

How is this happening? To start with, for the first time software producers are providing software that is not copy protected. This allows for backup and working copies to be easily made. Now you can have multiple copies of handy programs on many disks, freeing you up from playing musical disks. Beyond this there has been an even bolder step taken by some publishers. They state you can utilize their product in your own software without any penalty and at nominal cost. The usual agreement is that you simply register yourself and the product with the publisher and give acknowledgement of the use of the program. Penguin Software has done this with a number of their graphics packages. In particular I cite their Graphics Magician Picture Painter which is not copy protected and allows for its use in other products. Indeed, many people have taken advantage of the offer. In permitting use of the Graphics Magician, Penguin has saved people hours of laboriously drawing graphics, since it allows you to create and save hundreds of pictures on a single disk where normally only 11-15 pictures would fit. Here is a perfect example of how this willingness to share ideas frees up an author to do what he otherwise might not be able to do because of time expenditure or lack of expertise. He suddenly can add professional graphics to a software package that he is working on without any difficulty. He is not forced to learn what may be a completely foreign area of programming, but can instead benefit from someone else's expertise and experience.

MICRO feels that its place is one of a disseminator of knowledge, a place where people come to learn new things and share what they have learned. In this spirit we encourage people to **incorporate** what they discover in MICRO in their own work. The word **incorporate** is very significant in this context. If you are just using the material for your own personal benefit, then that is your right. That's why you buy MICRO in the first place.

However, MICRO can not allow its **major programs** to be copied and distributed by others — be they individuals, companies, computer clubs, etc. This would lessen the marketability of MICRO Magazine, the MicroDisks, books and software packages. The **smaller programs** and **utility routines** are a different matter. If you have a project that can benefit by **incorporating** some MICRO material, please contact us. Normally we will grant you permission to incorporate the material in your product, subject to signing a license that protects all parties and agreeing to a proper acknowledgement. In this way we feel we serve you better and make a greater pool of ideas available to more people. Perhaps a program that we publish will find its way into the hands of someone who will turn it into something we can use. And then, in turn, we may be inspired to create something else which will start the circle again. The end result is a continued growth personally and professionally for all involved - you and MICRO.

*Mark S. Morano*

Mark S. Morano  
Technical Editor

## On The Cover

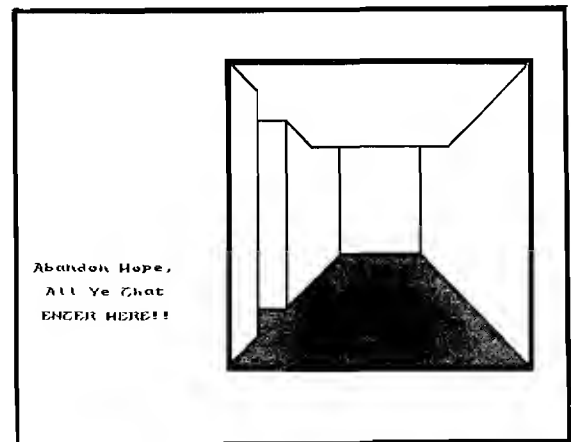

The tortuous passageways of Carnaervon Castle in Wales are the scene of our 3-D Maze. The usual warning is, of course, given to all foolish enough to enter, printed with the Atari/Epson custom characters offered by Mike Bassman's program.

*Photo by Cindy Kocher*

## Featured This Month

This month we offer eight complete major programs on a variety of topics, plus an excellent look at the 68000 machines and their operating systems.

**Truly 3-D Mazes** — generate truly 3-D mazes with a minimum of effort and memory. You get a rat's-eye view of the maze corridors as you "walk" through! And it all starts with a cube and 3 1/2K of RAM!

**Alter Track and Sector** — allows the user to dump, in hex, any sector on a disk with VIC/Commodore format, then modify any byte in that sector. Rewrite lost headers without loss of data!

**Extended Precision Arithmetic** — if greater mathematical precision is needed than is usual in BASIC, for statistical calculations perhaps, then this is the program for you. An interesting application is included in what may be the only program for calculating the lunar-based Jewish Calendar.

**Relocatable Step/Trace** — this step and trace routine can be easily moved to any part of a program.

**The UCSD p-System** — a careful, lucid explanation of how the fast, flexible p-system works and why it is becoming THE 68000 Operating System. Also, a review of six 68000-based microcomputers which puts the new systems in perspective.

**Atari Character Printer** — creating an unending array of different character fonts on your Atari screen can be fun, but now you can also print them out on paper with complete accuracy!

**Useful Math Functions** — save time and mathematical aggravation with a collection of defined functions.

**C-64 Graphic Dump** — this "perfect" dump works either in HiRes or multi-color, allows large size printouts and is very fast. This month, learn to interface 5 major commercial packages - whatever you generate you can now dump.

**HILISTER** — highlighting lines of text and programs can be useful for emphasis or clarity when discussing material on the screen in business meetings, classrooms, seminars. This program also allows easy movement within a program or text.

**MACRO™**

# Announcing ... TOTL. MONEYMINDER

FOR THE COMMODORE 64™

The home accounting package that will make your budget, not break it! **ONLY \$39.95**

**POWER  
PERFORMANCE  
& CLASS**



**TOTL**  
SOFTWARE, INC.  
quality you can afford



### Money-Saving Bonus Paks of 64 Software

(BP-1)—(disk)  
**totl.text/  
totl.speller/totl.label**  
reg. price \$103 **NOW \$79**

(BP-2)—(disk)  
**totl.business/  
totl.time manager/  
totl.infomaster/totl.text**  
reg. price \$228 **NOW \$159**

(BP-3)—(disk)  
**totl.infomaster/  
totl.text/totl.speller**  
reg. price \$129 **NOW \$99**

(BP-4)—(disk)  
**totl.text/  
totl.speller/  
research assistant**  
reg. price \$118 **NOW \$89**

(BP-5)—(tape)  
**totl.text/totl.label**  
reg. price \$60 **NOW \$49**

Commodore 64 and VIC 20 are trademarks of Commodore Business Machines Inc.

### INFORMATION AND ORDER COUPON

	TAPE	DISK
TOTL.TEXT 2.0 (VIC + 8K)	<input type="checkbox"/> 24.95	<input type="checkbox"/> 28.95
TOTL.TEXT 2.5 (VIC + 16K)	<input type="checkbox"/> 34.95	<input type="checkbox"/> 38.95
TOTL.LABEL 2.1 (VIC + 16K)	<input type="checkbox"/> 19.95	<input type="checkbox"/> 23.95
TOTL.TIME MGR. 2.1 (VIC + 8K)	<input type="checkbox"/> 29.95	<input type="checkbox"/> 33.95
RESEARCH ASST. 2.0 (VIC + 8K)	<input type="checkbox"/> 29.95	<input type="checkbox"/> 33.95
TOTL.BUSINESS 3.0 (VIC + 24K)	<input type="checkbox"/>	<input type="checkbox"/> 84.95
TOTL.TEXT 2.6 (C-64)	<input type="checkbox"/> 39.95	<input type="checkbox"/> 43.95
TOTL.SPELLER 3.6 (C-64)	<input type="checkbox"/>	<input type="checkbox"/> 34.95
TOTL.LABEL 2.6 (C-64)	<input type="checkbox"/> 19.95	<input type="checkbox"/> 23.95
TOTL.TIME MGR. 2.6 (C-64)	<input type="checkbox"/> 34.95	<input type="checkbox"/> 38.95
RESEARCH ASST. 2.0 (C-64)	<input type="checkbox"/> 34.95	<input type="checkbox"/> 38.95
TOTL.INFOMASTER 3.6 (C-64)	<input type="checkbox"/>	<input type="checkbox"/> 49.95
TOTL.BUSINESS 3.6 (C-64)	<input type="checkbox"/>	<input type="checkbox"/> 94.95
TOTL.MONEYMINDER 3.6 (C-64)	<input type="checkbox"/>	<input type="checkbox"/> 39.95
BONUS PAK # _____		

Check, Money Order or C.O.D.\* also accepted. C.O.D. Charges/Sales Tax \_\_\_\_\_  
\*C.O.D. orders \$2.00 additional (CA residents add 6 1/4% sales tax) Shipping & Handling **\$3.00**

Amount Enclosed \_\_\_\_\_  
FOR ORDERING ONLY—CALL OUR TOLL FREE NUMBERS  
Continental U.S. 1-800-351-1555, California 1-800-351-1551  
Hawaii and Alaska 415-943-7877

SEND MORE INFORMATION (no charge for catalog)

Name \_\_\_\_\_  
Street \_\_\_\_\_  
City \_\_\_\_\_ State \_\_\_\_\_ Zip \_\_\_\_\_  
Phone ( ) \_\_\_\_\_  MC  VISA  
Card # \_\_\_\_\_ Exp. Date \_\_\_\_\_

**TOTL**  
SOFTWARE, INC.

quality you can afford  
1555 Third Avenue  
Walnut Creek, CA 94596  
415/943-7877

**Publisher/Editor-in-Chief**

Robert M. Tripp

**Associate Publisher**

Cindy Kocher

**Production Manager**

Jennifer Collins

**Technical Editor**

Mark S. Morano

**Technical Editor**

Mike Rowe

**Advertising Manager**

William G. York

**Dealer Sales Manager**

Linda Hensdill

**Circulation Manager**

Linda Hensdill

**Office Manager**

Pauline Giard

**Shipping Director**

Marie Ann Wessinger

**Comptroller**

Donna M. Tripp

**Accounting**

Louise Ryan

**Contributing Editors**

Cornelis Bongers

Phil Daley

David Malmberg

John Steiner

Jim Strasma

Paul Swanson

Richard C. Vile, Jr.

Loren Wright

MICRO is published monthly by:  
 MICRO, Chelmsford, MA 01824.  
 Second Class postage paid at:  
 Chelmsford, MA 01824 and additional  
 mailing offices.  
 USPS Publication Number: 483470.  
 ISSN: 0271-9002.  
 Send subscriptions, change of address,  
 USPS Form 3579, requests for back issues  
 and all other fulfillment questions to:  
 MICRO  
 P. O. Box 6502  
 Chelmsford, MA 01824  
 or call 617/256-3649.  
 Subscription Rates: (per year):  
 U.S. \$24.00 or \$42.00 for two years  
 Foreign surface mail: \$27.00  
 Air mail: Europe \$42.00  
 Mexico, Central America, Middle East,  
 North Africa, Central Africa \$48.00  
 South America, South Africa, Far East,  
 Australia, New Zealand \$72.00

Copyright © 1984 by MICRO.  
 All Rights Reserved.

# MICRO™

for the **Serious Computerist**

## AUGUST 1984

### 15 Relocatable Step/Trace

*Chester H. Page*

Step and Trace program can be moved easily to any part of the program.

### 19 Constructing Truly 3-D Mazes

*Dr. Alan Stankiewicz*

Get a rat's-eye view of the maze corridors as you "walk" through them.

### 28 Graphic Print for C-64, Part 2

*Michael J. Keryan*

Interface with major commercial packages to create a full-page graphic printouts.

### 32 Alter Track and Sector

*Edwin L. King*

Rewrite any sector on a disk without loss of data.

### 36 The UCSD p-System: DeFacto Standard 68000 Operating System?

*Paul Lamar & Richard Finder*

A careful, lucid explanation of p-System and a comparison of six 68000-based computers.

### 41 Atari/Epson Custom Characters

*Mike Bassman*

Create and transfer almost unlimited customized alphabets to paper — accurately.

### 47 Extended Precision Arithmetic in BASIC

*Rolf B. Johannesen*

Greater mathematical precision and a way to calculate the Jewish Lunar Calendar.

## 52 HILISTER — A Study and Teaching Aid

*J. Morris Prosser*

Move easily within your programs and highlight parts of text or listings for emphasis, drama, clarity.

## 58 Useful Functions — Part 3

*Paul Garrison*

Save time and mathematical aggravation with a compilation of defined functions.

## 65 Interface Clinic: A Major Hardware Interface

*Ralph Tenney*

Design a major hardware interface - a receiver board for the 32K CoCo.

## Product Reviews

- |  |  |
|--|--|
| <p>11 <b>When I'm 64</b>      Sophisticated music synthesizer with vocal parts and animated face.</p> <hr/> <p>11 <b>BASIC Building Blocks</b>      Over 60 sample programs describe all facets of beginning programming.</p> <hr/> <p>11 <b>Write Now!</b>      Professional word processor with 80 column display, compatible with most printers.</p> <hr/> <p>12 <b>Songwriter</b>      Songs are recorded in a piano-roll style, making song composing fun and easy.</p> <hr/> <p>12 <b>Clone Master</b>      A disk utility designed to create backup copies of all or parts of user-owned disks.</p> | <p>12 <b>Advanced System Editor</b>      An extended Pascal System Editor with many enhancements and special features.</p> <hr/> <p>13 <b>Total Health</b>      A personal health monitor to keep track of nutrition on a daily basis.</p> <hr/> <p>13 <b>Commodore 64 Music Master</b>      Over 50 BASIC music programs to enjoy and learn with.</p> <hr/> <p>14 <b>Magic Memory</b>      Address-book type of data-base system for the Apple.</p> <hr/> <p>14 <b>64 Doctor</b>      Total diagnostic program for the C64.</p> <hr/> <p>14 <b>Computer Mechanic</b>      Learn automotive diagnostic methods and keep track of auto maintenance.</p> |
|--|--|

## Departments

- |              |                      |                        |
|--------------|----------------------|------------------------|
| 2 Editorial  | 61 CoCo Bits         | 69 Catalog             |
| 3 Highlights | 68 Books             | 71 Lyte Bytes          |
| 8 Feedback   | 12 Reviews           | 72 Advertiser Index    |
| 10 Spotlight | 62 Commodore Compass | 72 Next Month in Micro |

# It all adds up...

## HOME COMPUTERS

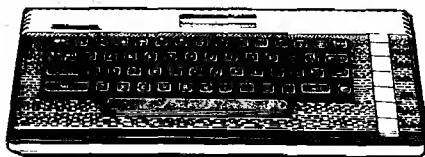

**800XL..... \$149**  
**800XL..... \$229**  
**WHILE SUPPLY LASTS**

850 Interface.....	\$159.00
1010 Recorder.....	\$71.99
1020 Color Printer.....	\$219.00
1025 Dot Matrix Printer.....	\$299.00
1027 Letter Quality Printer.....	\$289.00
1030 Direct Connect Modem.....	\$99.99
1050 Disk Drive.....	\$349.00
1064 Memory Module.....	\$125.00
Touch Tablet/Software.....	\$64.99
Light Pen/Software.....	\$72.99
CX22 Track Ball.....	\$39.99
7097 Atari Logo.....	\$74.99
4015 Pilot (Home).....	\$87.99
405 Pilot (Educ.).....	\$99.99
8036 Atari Pilot.....	\$77.99
5049 VisiCalc.....	\$149.99
488 Communicator II.....	\$119.99

1200XL.....	CALL
1480XL.....	CALL
CX30 Paddles.....	\$11.99
CX40 Joystick.....	\$7.99
4011 Star Raiders.....	\$31.99
4022 Pac Man.....	\$31.99
4025 Defender.....	\$31.99
8026 Dig Dug.....	\$31.99
8031 Donkey Kong.....	\$35.99
8034 Pole Position.....	\$37.99
8040 Donkey Kong Jr.....	\$33.99
8043 Ms Pacman.....	\$37.99
8044 Joust.....	\$37.99
8045 Pengo.....	\$33.99
8052 Moon Patrol.....	\$33.99
4003 Assembler.....	\$44.99
8126 Microsoft Basic I or II.....	\$64.99

## DISK DRIVES FOR ATARI

AT 88-SI.....	\$279.00	1000.....	\$299.00
AT 88-SI PD.....	\$299.00		
GT Drive.....	\$379.00		

## MEMORY BOARDS

Axlon 32K.....	\$59.99	Axlon 128K.....	\$299.00
Axlon 48K.....	\$99.99	Axlon 320K.....	\$849.00
Axlon 128K.....	\$299.00		

## ALIEN VOICE BOX

Atari.....	\$119.00	Apple.....	\$149.00
------------	----------	------------	----------

## DISKETTES

5 1/4" MD-1.....	\$24.99	5 1/4" SS/SD.....	\$18.49
5 1/4" MD-2.....	\$34.99	5 1/4" SS/DD.....	\$21.99
8" FD-1.....	\$39.99	5 1/4" DS/DD.....	\$26.99
8" FD-2.....	\$49.99		

## CONTROLLERS & JOYSTICKS

Joystick.....	\$21.99	Joystick.....	\$41.99
3-way Joystick.....	\$22.99	Atari Single Fire.....	\$12.99
Power Grip.....	\$21.99	Atari Switch Hitter.....	\$15.99
BOSS Joystick.....	\$17.99	Apple Paddles.....	\$34.99
ATARI/VIC Trak Ball.....	\$24.99	IBM Paddles.....	\$34.99
Apple Trak Ball.....	\$54.99	IBM Joystick.....	\$46.99
Apple Analog.....	\$37.99		

## Koala

Atari (ROM).....	\$79.99	IBM.....	\$99.99
C-64 (ROM).....	\$79.99	Apple/Franklin.....	\$85.99

## PRINTERS

AT-100 Atari Interface Printer.....	\$239.00	MANHESMAN TALLY.....	\$589.00
GP-100 Parallel Interface.....	\$199.00	160L.....	\$799.00
GP-550 Atari Bidirectional.....	\$319.00	180L.....	\$799.00
GP-700 Atari Color Printer.....	\$489.00	Spirit 80.....	\$309.00
GP-550 Parallel Printer.....	\$269.00		
		NEC.....	
		8023 Dot Matrix.....	\$389.00
		8025 Dot Matrix.....	\$669.00
		2010 15.30.....	\$749.00
		3510.15.30.....	\$1369.00
		7710.15/30.....	\$1799.00
		OKIDATA.....	
		82, 83, 84, 92, 93, 2350, 2410.....	CALL
		OLYMPIA.....	
		Compact 2.....	\$479.00
		Compact R0.....	\$509.00
		ESW 3000.....	\$1449.00
		SMITH CORONA.....	
		TP-1000.....	\$449.00
		Tractor Feed.....	\$119.00
		SILVER REED.....	
		500 Letter Quality.....	\$449.00
		550 Letter Quality.....	\$549.00
		770 Letter Quality.....	\$899.00
		STAR.....	
		Gemini 10X.....	\$299.00
		Gemini 15X.....	\$399.00
		Serial Board.....	\$75.00
		Radix 10.....	\$599.00
		Radix 15.....	\$699.00
		TOSHIBA.....	
		1340.....	\$889.00
		1351.....	\$1899.00
		TRANSTAR.....	
		120P.....	\$489.00
		130P.....	\$849.00
		315 Color.....	\$469.00

## MODEMS

Volksmodem.....	\$59.99	J-Cat.....	\$99.99
Mark II Serial.....	\$79.99	Cat.....	\$139.00
Mark VII (Auto Ans/Auto Dial).....	\$99.99	Smart Cat 103.....	\$179.00
Mark XII (1200 Baud).....	\$299.99	Smart Cat 103/212.....	\$399.00
Mark TR8-80.....	\$99.99	AutoCat.....	\$219.00
9 Volt Power Supply.....	\$9.99	212 AutoCat.....	\$549.00
		Apple Cat II.....	\$249.00
		212 Apple Cat.....	\$449.00
		Apple Cat 212 Upgrade.....	\$299.00
		PC Cat Access 1 3 3.....	\$399.00
		ZENITH.....	
		ZT1.....	\$339.00
		ZT10.....	\$309.00
		ZT11.....	\$369.00

## MONITORS

300 Green.....	\$149.00	SC 100 Color.....	\$269.00
300 Amber.....	\$159.00	SG-1000 Green.....	\$129.00
310 Amber.....	\$169.00	SA-1000 Amber.....	\$139.00
Color 1.....	\$279.00		
Color 1 Plus.....	\$299.00	TAXAN.....	
Color 2 Plus.....	\$419.00	210 Color RGB.....	\$209.00
Color 3.....	\$349.00	400 Med-Res RGB.....	\$319.00
Color 4T IBM.....	\$699.00	415 Hi-Res RGB.....	\$439.00
		420 Hi-Res RGB (IBM).....	\$489.00
		100 12" Green.....	\$125.00
		105 12" Amber.....	\$135.00
		USI.....	
		P1 1 9" Green.....	\$99.99
		P1 2 12" Green.....	\$119.99
		P1 3 12" Amber.....	\$129.99
		P1 4 9" Amber.....	\$119.99
		1400 Color.....	\$269.99
		QUADRAM.....	
		Quadchrome 8400 Color.....	\$519.00
		ZENITH.....	
		ZVM122 Amber.....	\$99.99
		ZVM123 Green.....	\$89.99
		ZVM124 IBM-Amber.....	\$149.00
		ZVM131 Color.....	\$309.00
		ZVM133 RGB.....	\$429.00
		ZVM135 RGB Composite.....	\$469.00

# COMPUTER MAIL ORDER

west  
**800-648-3311**  
 In NV call (702)588-5654, Dept. 125  
 Order Status Number: 588-5654  
 P.O. Box 6689  
 Stateline, NV 89449

canada  
 Ontario/Quebec 800-268-3974  
 Other Provinces 800-268-4559  
 In Toronto call  
 (416)828-0866, Dept. 125  
 Order Status Number: 828-0866  
 2506 Dunwin Drive, Unit 3B  
 Mississauga, Ontario, Canada L5L1T1

east  
**800-233-8950**  
 In PA call (717)327-9575, Dept. 125  
 Order Status Number: 327-9575  
 Customer Service Number: 327-1450  
 477 E. 3rd St., Williamsport, PA 17701

No risk, no deposit on C.O.D. orders and no waiting period for certified checks or money orders. Add 3% (minimum \$6) shipping and handling on all orders. Larger shipments may require additional charges. NV and PA residents add sales tax. All items subject to availability and price change. Call today for our catalog.

# the best prices

## APPLE/FRANKLIN DISK DRIVES MICRO-SCI

A2	\$219 00
A40	\$299 00
A70	\$319 00
C2 Controller	\$79 99
C47 Controller	\$89 99

### RANA

Elite 1	\$279 00
Elite 2	\$389 00
Elite 3	\$589 00

### APPLE IIe STARTER PACK

64K Apple IIe, Disk Drive & Controller,  
80 Column Card, Monitor II & DOS 3.3  
**COMPLETE.....CALL**  
Call on all other Apple Models



ACE 1000 Color Computer.....CALL  
ACE PRO PLUS System.....CALL  
ACE 1200 Office Mgmt. System.....CALL  
ACE PORTABLES.....CALL

## MBC 850.....CALL MBC 855.....CALL MBC 855-2.....CALL

MBC 1100	\$1499.00
MBC 1180	\$1899.00
MBC 1200	\$1849.00
MBC 1250	\$2099.00
PR 5500 Printer	\$599.00

## SANYO

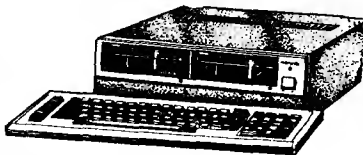

## HP HEWLETT PACKARD



HP 71B	\$419.99
41CV	\$189.99
41CX	\$249.99

HP 11C	\$62.99
HP 12C	\$92.99
HP 15C	\$92.99
HP 18C	\$92.99
HP 75D	\$879.99
HPIL Module	\$98.99
HPIL Cassette or Printer	\$359.99
Card Reader	\$143.99
Extended Function Module	\$63.99
Time Module	\$63.99

## SHARP



PC-1800A	\$188.99
PC-1250A	\$88.99
CE-125 Printer/Cassette	\$128.99
CE-150 Color Printer/Cassette	\$171.99
CE-155 8K RAM	\$93.99
CE-161 16K RAM	\$134.99

## NEC



PC-8221A Thermal Printer	\$149.99
PC-8281A Data Recorder	\$99.99
PC-8201-06 8K RAM Chips	\$105.00
PC-8206A 32K RAM Cartridge	\$329.00

## Commodore

CBM 8032	\$899
CBM 8096	\$869.00
CBM 9000	\$999.00
B128 80	\$769.00
8032 to 9000 Upgrade	\$499.00
2031 LP Disk Drive	\$299.00
8050 Disk Drive	\$949.00
8250 Disk Drive	\$1199.00
4023 Printer	\$379.00
8023 Printer	\$589.00
6400 Printer	\$1399.00
Z-RAM	\$499.00
Silicon Office	\$699.00
The Manager	\$199.00
SoftROM	\$125.00
VisiCalc	\$159.00

### PROFESSIONAL SOFTWARE

Word Pro 2 Plus	\$189.00
Word Pro 3 Plus	\$189.00
Word Pro 4 Plus/5 Plus each	\$279.00
InfoPro	\$179.00
Administrator	\$399.00
Power	\$79.99

### 8X-84 Portable.....\$859

CBM 84	\$199
C1541 Disk Drive	\$249.00
C1530 Datasette	\$69.99
C1520 Color Printer/Plotter	\$129.00
M-801 Dot Matrix Printer	\$219.00
C1528 Dot Matrix/Serial	\$299.00
C1702 Color Monitor	\$259.00
C1311 Joystick	\$4.99
C1312 Paddles	\$11.99
C1600 VIC Modem	\$89.99
C1650 Auto Modem	\$89.99
Logo 64	\$49.99
Pilot 64	\$39.99
Word Pro 64 Plus	\$59.99
Calc Result 64	\$65.99
Calc Result Easy	\$39.99
Codewriter 64	\$75.99
MCS 801 Color Printer	\$499.00
DPS 1101 Daisy Printer	\$459.00
Magic Voice Speech Module	\$54.99
Desk Organizer Lock	\$49.99
Vidtex Telecommunications	\$34.95

### MSD

SD1 Disk Drive	\$349.00
SD2 Disk Drive	\$599.00

### NEC PRINTERS

NEC 2050	\$899.00
NEC 3550	\$1669.00

### PERCOM/TANDON

5 1/4" 320K Floppy	\$219.00
8 Meg Hard w Controller	\$1049.00
10 Meg Hard w Controller	\$1349.00
20 Meg Hard w Controller	\$1899.00

### VISICORP

VisiCalc IV	\$159.00
VisiWord +	\$249.00
Visi-on Application Manager	\$79.99
Visi-on Calc	\$289.00
Visi-on Graph	\$179.00
Visi-on Word	\$249.99
Optical Mouse	\$189.99

### AST RESEARCH

Six Pak Plus	from \$279.00
Combo Plus II	from \$279.00
Mega Plus	from \$309.00
IO Plus	from \$139.00

### QUADRAM

Quadlink	\$479.00
Quadboard	as low as \$289.00
Quad 512 Plus	as low as \$249.00
Quadcolor	as low as \$219.00
Chronograph	\$89.99
Parallel Interface Board	\$89.99
64K RAM Chips Kit	\$59.99



## ZENITH data systems

### PC COMPATIBLE 16 BIT SYSTEMS

Z-150 PC Z-160 PC  
Call for price and configurations

### SOFTWARE

	C-64	Atari	IBM	Apple
Electronic Arts				
One on One	\$29.99	\$29.99	\$29.99	\$29.99
Music Construction	\$29.99	\$29.99	\$29.99	\$29.99
Pinball Construction	\$29.99	\$29.99	\$29.99	\$29.99
Cut & Paste	\$39.99	\$39.99	\$39.99	\$39.99
Hard Hat Mack	\$29.99	\$27.99	\$27.99	\$27.99
InfoCom				
Witness	\$29.99	\$29.99	\$29.99	\$29.99
Intruder	\$29.99	\$29.99	\$29.99	\$29.99
Dreadful	\$29.99	\$29.99	\$29.99	\$29.99
Planetfall	\$29.99	\$29.99	\$29.99	\$29.99
Enchanter	\$29.99	\$29.99	\$29.99	\$29.99
Zork I, 2, 3 ea	\$27.99	\$27.99	\$27.99	\$27.99
Suspended	\$29.99	\$29.99	\$29.99	\$29.99
Sorcerer	\$29.99	\$29.99	\$29.99	\$29.99
AtariSoft				
Jeopardy	\$35.99	NA	\$28.99	\$28.99
Moer Patrol	\$35.99	NA	\$28.99	\$28.99
Ms PacMan	\$35.99	NA	\$28.99	\$28.99
PacMan	\$35.99	NA	\$28.99	\$28.99
Donkey Kong	\$35.99	NA	\$28.99	\$28.99
File Position	\$35.99	NA	\$28.99	\$28.99
Spinnaker				
Aerobics	\$28.99	\$28.99	\$28.99	\$28.99
Trans	\$24.99	\$24.99	\$24.99	\$24.99
Adventure Creature	\$24.99	\$24.99	\$24.99	\$24.99
Argoan Voyage	\$24.99	\$24.99	\$24.99	\$24.99
Snooper Troops 1,2 ea	\$28.99	\$28.99	\$28.99	\$28.99
Traction Power	\$22.99	\$22.99	\$22.99	\$22.99
Archipel Zoo	\$22.99	\$22.99	\$22.99	\$22.99
In Search of	\$24.99	\$24.99	\$24.99	\$24.99
Footmaker	\$22.99	\$22.99	\$22.99	\$22.99
Kinder Camp	\$17.99	\$17.99	\$17.99	\$17.99
Dynatech				
Code Writer	\$79.99	\$79.99	\$175.99	\$156.99
VisiCorp				
VisiCalc	\$159.99	\$149.99	\$159.99	\$159.99
VisiCalc Advanced	NA	NA	NA	\$289.99
pfs:				
Write	NA	NA	\$89.99	\$89.99
Draw	NA	NA	\$79.99	\$79.99
Report	NA	NA	\$79.99	\$79.99
File	NA	NA	\$89.99	\$79.99
Solutions	NA	NA	\$26.99	\$16.99
1000 of Titles				

# COMPUTER MAIL ORDER

west

800-648-3311

In NV call (702)568-5654, Dept. 125  
Order Status Number: 588-5654  
P.O. Box 6889  
Statenline, NV 89449

canada

Ontario/Quebec 800-268-3974  
Other Provinces 800-268-4559

In Toronto call  
(416)828-0866, Dept. 125  
Order Status Number: 828-0866  
2505 Dunwin Drive, Unit 3B  
Mississauga, Ontario, Canada L6L1T1

east

800-233-8950

In PA call (717)327-9575, Dept. 125  
Order Status Number: 327-9576  
Customer Service Number: 327-1450  
477 E. 3rd St., Williamsport, PA 17701



CANADIAN ORDERS: All prices are subject to shipping, tax and currency fluctuations. Call for exact pricing in Canada. INTERNATIONAL ORDERS: All orders placed with U.S. offices for delivery outside the Continental United States must be pre-paid by certified check only. Include 3% (minimum \$5) shipping and handling. EDUCATIONAL DISCOUNTS: Additional discounts are available to qualified Educational Institutions. APO & FPO Add 3% (minimum \$5) shipping and handling.

## Question Mark Unraveled

Dear Drs. Ferra & Cortese:

After many hours of research, skipping meals, and closing down the library several times, I believe I have uncovered the secret to the North American Rosetta stone discovered by Drs. Ferra and Cortese.

The communications of the Toltecs and Aztecs using Pyramidems of the Moon, I found out, was somewhat slow due to the serial pottery interface required. This led to much experimentation and finally the development of the much more efficient Pyramodems of the Sun. These were parallel devices and required only minor modification to the Adobe software. With the new hardware, everyone had access to the Teotihuacan data bases.

A drawback still remained in data transmission. An Alpha Spatial Scan [ASS] was needed to provide proper displaying on the Ceramic Refined Tritons [CRTs]. Plumed Serpentine Software, Inc., with main offices at the Temple of Quetzalcoatl, overcame the

problem and provided the solution and test data to all who requested it.

The test data could be obtained on clay or the more reliable rockettes. It was in 126 position spiral form and was read from the outside inward, breaking on every seventh position creating 18 new positions. The graphic representations of the 18 positions was then reversed and message "WELCOME TO LYTE BYTES" was displayed.

Oliver H. Wardlow, Jr.  
Topeka, KS

### Editor's Note:

*Our thanks to Dave Nicklas of Danvers, MA who was the first to send in the correct solution.*

### Unusual Software Sought

Dear Sirs:

I am interested in point-of-sale cash registers, bar code readers, and software for liquor store applications.

Cleo McCoy  
Marietta, GA

Dear Sirs:

I am interested in Apple II Plus software and related hardware for use in quality control of nuclear fuel.

Hyun Tae Kim  
Korea Advanced Energy Research Institute  
Chung-Nam, Korea

Dear Sirs:

I am writing to ask if you know where I might be able to obtain hardware and software for an Apple II Plus to operate and control a fish nursery. I am very interested in any information about setting up and operation of computerized fish farms/nurseries.

Joseph G. Bloechl  
APO New York

### Editor's Note:

*If any readers can suggest software to fit any of the above requests, please send name of package, publisher name and address to Letters Editor at Micro.*

(continued)



CONSUMERS GUIDE ONE OF THE BEST PROGRAMS AVAILABLE FOR THE APPLE COMPUTERS  
SOFTALK IT PAYS FOR ITSELF APPLE ORCHARD FIRST RATE INTERNAL AND EXTERNAL MAINTENANCE OF YOUR COMPUTER  
NIBBLE MAGAZINE THIS PACKAGE SHOULD BE IN THE LIBRARY OF EVERY APPLE USER  
POPULAR COMPUTING FIRST LEVEL DIAGNOSTICS PACKAGE  
MATHEMATICS & COMPUTER EDUCATION EASY TO USE A PERFECT PACKAGE  
IN CIBER DOES ONE JOB VERY WELL INDEED!

## MASTER DIAGNOSTICS

There is only one thing more important than your



# Maintaining it.

HOW MANY DISKETTES HAVE YOU INITIALIZED WITH YOUR DISK DRIVES RUNNING TOO FAST OR TOO SLOW? THINK ABOUT WHAT THAT COULD MEAN

DO YOU KNOW THAT THE DRIVE SPEED OF YOUR APPLE SHOULD BE AS CLOSE TO 300 RPM AS POSSIBLE? LIKE A RECORD OR TAPE SYSTEM VARIES WITH MOTOR SPEED SO DOES A DISKETTE

WHEN WAS THE LAST TIME YOU CLEANED THE READ/WRITE HEADS OF YOUR DRIVES? THEY SHOULD HAVE BEEN CLEANED LAST MONTH AND WITH OUR PROGRAMMED UTILITIES YOU COULD DO SO AT THE PUSH OF A BUTTON

HOW ABOUT THE WRITE PROTECT SWITCH? IS IT WORKING PROPERLY SO YOU WON'T DESTROY YOUR PROGRAM DISKETTE OR PROTECTED DATA? THERE'S LOTS MORE AND IT WILL ONLY TAKE 15 MINUTES A MONTH TO KEEP YOUR HIGH TECHNOLOGY EQUIPMENT RUNNING AT HIGH PERFORMANCE PREVENT PROBLEMS OR DIAGNOSE PROBLEMS AND SAVE YOURSELF ONE OF THOSE DAYS

WITH MASTER DIAGNOSTICS ANYONE CAN DO IT.

THE PROGRAM THAT PAYS FOR ITSELF

WHEN ORDERING SPECIFY  
version II & II plus or version IIe



- master diagnostics \$55.00  
 master diagnostics + plus \$75.00

DIAL 1-800-835-2246

### THE TESTS INCLUDE

MOTHERBOARD ROM TEST	DISK DRIVE SPEED CALIBRATION	MONITOR SKEWING TESTS
APPROX. CARD TEST	DRIVE HEAD READ/WRITE TEST	MONITOR & MODULATOR CALIBRATION
INTERFER CARD TEST	WRITE PROTECT SWITCH TEST	MONITOR TEST PAGE TEST
MOTHERBOARD RAM TEST	DRIVE HEAD CLEANING ROUTINES	MONITOR TEST PATTERN
10K RAM CARD TEST	DISK DRIVE MAINTENANCE	MONITOR A TV YORE ALIGNMENT
AUX RAM TEST	DO HAYES MACROMODEM II TEST	LSI RES. COLOR TESTS
80 COLUMN CARD TEST	PRIDDLE & SPEAKER TEST	HI RES. COLOR TESTS
PARALLEL CARD TEST	PRIDDLE & BUTTON TEST	LSI/SQUID PATTERNS
SPEAKER FUNCTION TEST	PRIDDLE DRIFT TEST	PRINT HEAD SOLDER GENERATOR
SQUARE WAVE MODULATION	INTERNAL MAINTENANCE	GENERAL MAINTENANCE
ON BOARD HELP	FORTY PAGE MANUAL	*APPLE II

### THE - PLUS

Master Diagnostics - Plus provides everything needed to maintain your computer. The entire package is housed in our own molded case to protect against static electricity, x-ray and other contaminants.

- Included in the kit is:
- THE DIAGNOSTICS DISKETTE
  - FORTY PAGE PROCEDURE MANUAL
  - HEAD CLEANING KIT
  - CRT SCREEN CLEANER
  - COMPUTER/DRIVE HOUSING CLEANER
  - REUSEABLE CHAMOIS TIPPED WANDS

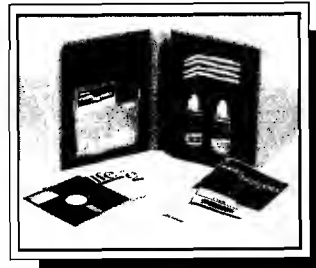

## NIKROM

Technical Products, Inc.  
25 Prospect Street, Leominster MA 01453

## More on the 68000

Gentlemen:

I read with interest Paul Lamar's article on the 68000 in your June issue. Like Paul, I am enthusiastic about the 68000. As I repeatedly read in that issue, 68000 will indeed be the 6502 of the 1980's. If I were more tactful, I would refrain from pointing out that I made exactly that assertion to Bob Tripp three years ago.

On page 45, Paul has an incomplete quote from the 'DTACK GROUNDED' newsletter. In its incompleteness, it appears to be wrong. Paul asserts that the 68000/16081 combination can perform a double precision multiply in 23 microseconds and that is 3 times faster than an 8086/8087 combination. Since most folks familiar with the 8087 know it performs a double precision multiply in 27.4 microseconds, the figures do not appear to jibe.

A more complete explanation: the 12.5MHz 68000/6.25MHz 16081 can perform the double precision operation  $A = B * C$ , where A, B and C are double-precision operands kept in memory, in 23 microseconds. A 5MHz 8086/8087 takes 9 microseconds to load A, 9 microseconds to load B, 27.4 microseconds to perform the multiplication, and 20 microseconds (!) to store the result in memory: a total of 65.4 microseconds. That does not include the 'EA' (effective address) time, so a practical Intel system is in fact about 3 times slower than the 68000/16081 system. (The 23 microseconds for the 68000/16081 system represents an actual measurement of a loop repeated 1,000,000 times with the loop overhead subtracted.)

As you can see, the 8086/8087 system has a considerable overhead associated with transferring floating point operands to and from memory. The reason is that the data representation used by the 8087 internally is not the same which is stored in memory, and the conversion takes an appreciable amount of time. By way of contrast, the Nat Semi 16081 math chip uses an internal data representation which is identical to that which is stored in memory. Also, the actual multiplication takes place much faster - 10 microseconds vs. 27.4.

There are other differences between the 8087 and the 16081, such as the fact that the 8087 does most transcendental calculations as a single command and the 16081 does not, so the 16081 is going to be a lot faster than the 8087 when performing linear algebra or matrix math (where most operands are kept in memory) while the 8087 will be faster than the 16081 when calculating square roots or arc tangents. Nothing is simple these days, is it?

A very limited number of samples of 8 MHz 8087s exist and so does a very limited number of samples of 10MHz 16081s. As far as us peasants are concerned, neither part really exists right now.

Finally, the application note which Nat Semi is preparing shows a 68000 slowed down to the same clock speed as the 16081, which is the way the Nat Semi 16032 microprocessor has to work with the 16081. Nat Semi does not want anybody to know about the way we use the 16081, running at half the clock speed of the 68000 because

such a system can outrun the Nat Semi combo when nonfloating point operations are being performed.

For the record, Digital Acoustics shipped the first commercial 68000/16081 system in Dec. '83. To the best of our knowledge, we are the only ones actually shipping product today. The fact that lots of folks are actively working on such systems may have something to do with the fact that we published a schematic and a four-page technical explanation in our newsletter 25, [10/22/83].

Hal W. Hardenbergh  
President, Digital Acoustics, Inc.

**MACRO**

## AN AFFORDABLE 68000 System for your Apple!

68000 Mainframe architecture is now available for 8 bit systems with **McMILL**.

**McMILL** features the new MC68008 member of the M68000 family, and offers Apple II, IIe users a no frills, low cost 68000 based development system.

LEARN MORE ABOUT THE "HEART" OF THE LISA & MACINTOSH SYSTEMS WHILE STAYING WITH YOUR PRESENT II OR IIe SYSTEM.

McMILL IS BOTH SOURCE & OBJECT CODE COMPATIBLE WITH ALL 68000 PROGRAMS, MAKING YOUR APPLE A 68000 BASED DEVELOPMENT SYSTEM!

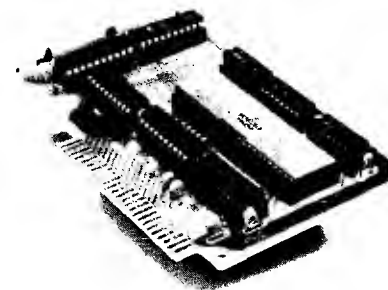

**McMILL** is the 68008 based coprocessor board that:

- \* Fits into any slot on Apple II, IIe or Apple compatible.
- \* Uses Apple memory and clock for true 6502/68008 coprocessing.
- \* Comes with ready to run 68000 Fig FORTH and a 6502/68000 MACRO cross Assembler.
- \* Carries a full one year hardware warranty.
- \* Features ultimate efficiency in design & power with a fully loaded system for UNDER \$300.00\*.

To order, see your local dealer or contact:

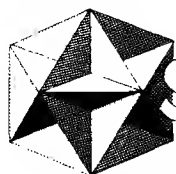

**STELLATION  
TWO**

The Lobero Bldg.  
Box 2342  
Santa Barbara, CA 93120  
(805) 966-1140 / 966-4964

Lisa/Macintosh, Apple are trademarks of Apple Computer Inc. Fig Forth offered as public domain from Mountainview Press. 6502/68000 Cross Assembler from S.C. Software Corp. McMILL trademark of Stellation Two Inc.

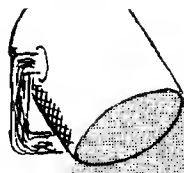

# Micro-Match Interface Series

## Distributor

Command Computer Corporation  
P.O. Box 5096  
Philadelphia, PA 19111

## Introduction

In this day and age of such a varied host of computers, peripherals and interfaces, one is left in a state of confusion as how to get them all together. Command Computer Corporation's 'Micro-Match' is a great step forward in helping to resolve this communication problem. It has been designed to 'take the guesswork and inefficiency out of interfacing or interconnecting.' What Micro-Match supports is micros to printers, CRT's, modems and plotters; micros to minis; and micros to mainframes. The product comes in two parts; a two volume product called Blueprints and a second product called Access Forum.

## Blueprints

Blueprints is a set of ready-to-use interfaces. There are indices by manufacturer and device type. These indices direct you to sections that list wiring specs, switches and jumpers, and any other pertinent information. Cross-referencing makes it easy and fast to find the specifications and information you need to interface two products. In the Wiring Specs section whether an interface is parallel or serial is confirmed, and a diagram is included showing the actual connections that need to be made on both devices. Switches and jumpers is the other major section necessary in interfacing. This part clearly shows you how to configure your devices using diagrams and notes. The section entitled General Notes is gold mine of information that has been gathered into a handy and readable form. Covering grounding principles, cable length limits, cable wire types, checklists, plug types, and more, it is an invaluable aid in telecommunications. Also provided are Device Notes which show diagrams of the actual units, where the various ports, buttons and controls are located, showing all necessary views for a complete picture. Updating supplements will be provided to each Micro-Match user every quarter. These will keep the user up-to-date with new products and their interfaces.

Some of the specific computers and peripherals covered are: Altos, Apple, AST Research, California Computer Systems, IBM, Kaypro, Quadram, Tecmar, Televideo, Hayes, Novation, Anadex, C-Itoh, Comrex, Diablo, NEC, Epson, Okidata, and more. Additionally, users will be able to request 'custom interfaces' for devices not covered in Blueprints.

## Access Forum

The second product, Access Forum, is 'an on-going series of research reports that focus on important products and topics related to the interfacing of microcomputers and peripherals with mini and mainframe computers.' This section is not for the uninitiated but rather is designed with the data processing manager and professional in mind. It is an aid to these people who are searching for specific solutions to their interfacing problems in this area. The solutions that are focussed on are in the following areas: downloading/uploading data files between micros, minis, and mainframes; converting mini and mainframe software to micros; interfacing micros with mainframe-compatible tape drives, card readers, and special input/output devices; connecting micros with TELEX and commercial timesharing networks; micro upgrade paths; converting/porting programming languages; networking micros; converting protocols; interfacing graphics devices, graphics systems compatibility, etc.; integrating micros into 3270, SDLC, and SNA networks. For the users convenience two copies of the Forum are provided which can be easily removed and kept handy.

## Pricing

Both Blueprints and Access Forum can be purchased for \$690 per year. Beyond the initial products the price includes 'quarterly Blueprints supplements with interfaces for devices to be announced in the industry during the coming year, and three new Access Forum volumes on new micro-to-mini and micro-to-mainframe access products and solutions.'

## Conclusion

The need for such a product is clear given the ever increasing number of micros, minis, peripherals, etc. The problems associated with telecommunications are often aggravating, time-consuming and difficult. Micro-Match does indeed fill a niche that has been neglected. And it is what it says it is 'a complete, step-by-step system

that can be used by anyone having minimal computer experience to successfully implement a complete working interface between a wide variety of microcomputer devices and peripherals.' The Access Forum also is an invaluable source of state-of-the-art information as regards micro, mini, and mainframe interfacing. Combined both Blueprints and Access Forum are an investment that can save time, money and unnecessary problems.

Product Name: **When I'm 64**  
Equipment  
Req'd: Commodore 64 and disk drive  
Price:  
Manufacturer: The ALIEN Group  
27 West 23rd St.  
New York, NY 10010

**Description:** A sophisticated music synthesizer music system including vocal parts and an animated face. The disk is supplied with 30 short demo songs and a short instruction manual for generating your own music. With the addition of the ALIEN Group Voice Box, an graphics screen face also sing the lyrics of the song. In addition to all of the standard controls (envelope, etc.) the program also has controls for vibrato, glissando, and accents. Lyrics are entered in the phonetic alphabet.

**Pluses:** A screen editor is supplied to easily modify any of the synthesizer (sound chip) parameters, with immediate playback and correction of input songs. The notes and words are easily edited and the face animated to imitate the lyrics.

**Minuses:** Any program of this magnitude is going to be difficult to learn to use all its facets without much study.

**Skill level required:** No previous background assumed.

**Reviewer:** Phil Daley

---

Product Name: **BASIC Building Blocks**  
Equipment  
Req'd: Apple II,II+,IIe - DOS 3.3 (ProDOS available). Also available for Atari and C-64.  
Manufacturer: Micro Education Corp. of America  
285 Riverside Avenue  
Westport, CT 06880

**Description:** Disk 1: An interactive tutorial in the BASIC language using over 60 sample programs describing all facets of beginning programming -I/O, branching, arrays, strings, graphics and disk access. Disk 2: Basic Design Tool, a M/L runtime debugging tool to help in understanding how programs work or why they don't work. This program is worth the price of the package alone.

**Pluses:** While the sample programs are good for the beginning programmer, the BDT really makes the package interesting. You can set breakpoints by line number or variable name; run, trace or step the program; and switch between the program's screen display and the debugger display which includes preset variables and their values, the just executed statement and the next statement to be

executed, and stack information about FOR..NEXTs and GOSUBs. The documentation, while short is almost unnecessary due to program friendliness.

**Minuses:** BDT does take up 8K space (above HIMEM) and pushes the BASIC program above Text Page 2 (it uses Page 2 for its own display), so not all BASIC programs will fit in the leftover space. PEEKing the keyboard (\$C000) also won't work, although you can RUN past those points.

**Skill level required:** No previous knowledge for Disk 1. Some BASIC programming experience for Disk 2.

**Reviewer:** Phil Daley

---

Product Name: **Write Now!**  
Equipment  
Req'd: Commodore 64 with disk or tape and printer  
Manufacturer: Cardco, Inc.  
313 Mathewson  
Wichita, KS 67214

**Description:** A professional word processor with 80 column display for sample output, unlimited length documents, search and replace, multiple line headers and footers, justification, block copy and delete and compatibility with almost any printer. You can select screen colors, view help screens, get a disk directory, initialize a disk, rename or scratch files and more, all from within Write Now!

**Pluses:** Unless the file is very large (more than 16K), the program is very fast, since it is entirely in machine language. Usable memory is about 30K, but files can be chained together. The documentation is excellent with a very good index to find answers to any questions. There is also a cut-out card to indicate what the control/Commodore functions are.

**Minuses:** There is no word wrap! Words are broken at the end of the lines. You may be able to tell where you are in 80 column display, and you may not. It depends on the CRT. The search and replace does not function if you try to replace a character with nothing. There appears to be a bug - if you have a full file and replace something with a longer something, it will replace several before stopping, creating a file longer than allowed and full of gibberish at the end. Reloading a that saved file gives a Memory overflow error, which throws away all the gibberish at the end. The manual says that a joystick will move the cursor; mine didn't.

**Skill level required:** No previous experience required.

**Reviewer:** Phil Daley

Product Name: **Songwriter**  
Equipment  
Req'd: Commodore 64 and disk drive  
Price:  
Manufacturer: Scarborough Systems, Inc.  
25 North Broadway  
Tarrytown, NY 10591  
Author: Samuel Wantman

**Description:** An educational program that makes it fun to learn to write songs. Songs are recorded in a piano-roll style with simple editing commands to alter, add or delete notes. Songs can be saved on disk with 20 songs prerecorded. Tempo is variable; songs can be stopped anywhere and single stepped forwards or backwards. Sound quality is somewhat variable using the function keys.

**Pluses:** Entering songs is extremely simple whether entering from sheet music or original material. The duration is set (1/4, 1/8th note, etc.) and the pitch selected from a graphic keyboard with cursor keys or joystick. Playback can be immediate. The thorough documentation is easy to read and very complete. This program can easily be used by young children.

**Minuses:** The program only allows single voice parts. Unless you are interested in melody only, or have an Apple, this drawback defeats most of the usefulness of the Commodore sound chip. It also only allows limited sound adjustment.

**Skill level required:** No prior knowledge needed.

**Reviewer:** Phil Daley

---

Product Name: **Clone Master**  
Equip. Req'd: TRS-80 Color Computer,  
16K Disk Basic  
Price: \$34.95  
Manufacturer: Prickly-Pear Software  
9234 E. 30th Street  
Tucson, AZ 85710

**Description:** Clone Master is a disk utility which is designed to create backup copies of all or selected portions of user-owned diskettes. It is not designed or intended for use in the illegal copying of copyrighted software. It will run on 16K, 32K or 64K Color Computers with at least one disk drive. The program will check the RPM of the disk drive before beginning any backup work. If the drive is not within acceptable parameters, an error message will be issued to the effect that the drive speed needs adjusting. Double sided drives are also supported and backup can be done from one side to the other. Any range of disk tracks from 0 to 99, inclusive, may be backed up. Backup of partial diskettes is, therefore, possible.

1/3

**Pluses:** Clone Master will copy everything that is on a disk, including errors. It can be used to copy non-Color Computer diskettes as well, which makes it handy as a utility if you have other types of computers in addition

to the Color Computer. With 64K machines, the backup process uses the entire memory available to perform the backup, necessitating only three disk swaps for single disk drives as opposed to seven swaps for the Disk Basic Backup command. The RPM check feature is a good diagnostic test. Track step rates can be changed and the program itself can be custom tailored to a user's configuration and then permanently saved to disk for future use. Partial copying is a good feature and allows the user to copy only selected portions of a diskette.

**Minuses:** The user must know exact contents of a disk if partial backup is to be used. There is no provision in Clone Master to view the contents of any disk or the directory.

**Documentation:** The documentation consists of three typewritten pages; it is adequate to use the program. All features are discussed and described in the documentation and additional technical information is presented for those who may wish to modify the program for tailored execution.

**Skill level:** The program can be used by novice users with relative ease. It is completely menu driven and error messages are explained in depth in the documentation.

**Reviewer:** Norman Garrett

---

Product Name: **Advanced System Editor**  
Equipment  
Req'd: Apple II, II+, IIe - Apple Pascal  
Manufacturer: Volition Systems  
P.O. Box 1236  
Del Mar, CA 92014  
Author: Richard Gleaves

**Description:** ASE is an extended Pascal SYSTEM.EDITOR running under the Apple UCSD Pascal system. While fully compatible with the standard editor, including using all of the standard features and commands, it includes many enhancements and additional features making it much more versatile and easy to use. Files are not limited to memory size and may be as large as an entire disk. A disk directory, including the first line of the file, is available from within the editor. Multi-file editing is possible, making it easy to move sections from one file to another. ASE also has user definable function keys.

**Pluses:** The editor is much faster and has many more commands making text and program editing easier and more efficient. A backup of the original file is always saved in case of mistakes. It has a column command to move whole columns left or right. Installation is easy and the documentation is superb. If you write many Pascal programs, you need this editor.

**Minuses:** None noted.

**Skill level required:** Familiarity with UCSD Pascal.

**Reviewer:** Phil Daley

**MICRO**

Product Name: **Total Health**  
Equipment  
Req'd: Commodore 64 and disk drive  
Manufacturer: Computer Software Associates  
65 Teed Drive  
Randolph, MA 02368  
Author: Mark Baier

**Description:** A program for fitness and health enthusiasts which monitors and encourages good nutrition. The program has two parts: a file manager of daily food intake which keeps track of the calories, protein, fat and carbohydrates consumed on a daily basis; and a graphing program to plot your current status toward your final goal. The package includes a small manual that is not really needed due to the program's elegant simplicity.

**Pluses:** The program is easy to use and can be your own personal weight watcher. Like any dietary aid, it will encourage you to do well, but the hard part is to stick to your schedule. The list of foods could be larger, but there is a provision for adding your own values for unlisted foods.

**Minuses:** There aren't many input checks, so the program crashes relatively easily. I had several problems with the disk routines.

**Skill level required:** No prior knowledge necessary.

**Reviewer:** Phil Daley

---

Product Name: **The Commodore 64 Music Master**  
Equipment  
Req'd: Commodore 64 and cassette  
Manufacturer: Softtext, Inc.  
Cambridge, MA  
Author: James Vogel

**Description:** A tape of over 50 BASIC music programs for the C-64 with accompanying book describing how the programs work, variable listings and logic flow, utilities for exploring the ADSR, filters and frequency conversions, and suggestions for making your own music programs. The programs themselves are generally interesting and range from simple to complex. The documentation proceeds from a very beginning sound program, stepwise to more advanced topics.

**Pluses:** The programs are well documented and can easily be modified to help in understanding how they work. They include a wide range of topics and show how to use all of the features available in the SID chip. It is an excellent introduction to the sound capabilities of the C-64 in BASIC.

**Minuses:** None noted.

**Skill level required:** A small amount of programming experience (1 or 2 weeks) to be able to modify the programs.

**Reviewer:** Phil Daley

For the  
**Commodore 64**

# SuperTerm

New  
low price \$89<sup>95</sup>

Telecomputing

with a difference!



SuperTerm — the only software that communicates with them all! Information networks such as CompuServe; business and university mainframes; free hobby bulletin boards.

**Professionals and students:** SuperTerm's VT102 emulation gets you on-line in style. Advanced video features, graphics, full-screen editing, 80/132 column through sidescrolling, extended keyboard — perfect for EDT, DECmail, etc. Even download your workfiles and edit off-line! Full printer and editor support; other emulations available.

**Researchers and writers:** SuperTerm's built-in text editor helps you create, edit, print, save, send and receive text files — articles, stories, reports, inventories, bibliographies — in short, it's your **information work station**. Access CompuServe, Dow Jones Information Network, Dialog/Knowledge Index, Western Union's Easylink, The Source, and many more. Optional Sprinter accessory saves printing time and \$ (see below).

**Computer hobbyists:** Join in the fun of accessing hundreds of free bulletin board systems (BBS) for Commodore, Apple, TRS-80, etc. Text mode with all BBS systems; up/downloading with Commodore BBS systems (Punter protocol). Special protocol for up/downloading with other SuperTerm owners. Popular "redial-if-busy" feature for use with automodems.

Get the information you need, for business or for fun,  
with **the software that communicates with them all!**

Requires Commodore 64, disk drive, and suitable manual- or auto-modem. Printer optional. Software on disk w/ free backup copy. Extensive manual in deluxe binder.

## SuperTerm's SPRINTER Accessory . . . . . \$69<sup>95</sup>

With the Sprinter accessory, SuperTerm can perform **concurrent printing** — as text appears on your screen, it's simultaneously printed on your printer. Includes all necessary hardware for connecting your **parallel printer** and computer via the cartridge port. Simply plug-in and go. Free utility software for printing and listing as a stand-alone interface.

Requires parallel printer such as Epson, Gemini, Microline, C itoh (Min. speed 35 cps.)

Commodore 64 is a trademark of Commodore Electronics, Ltd.

**(816) 333-7200**

Send for a free brochure.



**MIDWEST  
MICRO inc.**

**MAIL ORDER:** Add \$1.50 shipping and handling (\$3.50 for C.O.D.); VISA/Mastercard accepted (card# and exp. date). MO residents add 5.625% sales tax. Foreign orders payable U.S. \$ U.S. Bank ONLY; add \$5 shp/hndlg.

311 WEST 72nd ST. • KANSAS CITY • MO • 64114

Product Name: **Magic Memory**  
Equipment  
Req'd: Apple II, II+, IIe - DOS 3.3  
Manufacturer: ARTSCI  
5547 Satsuma Ave.  
North Hollywood, CA 91601  
Author: Excutive Software, Inc.

**Description:** An address-book oriented data-base system utilizing either 40, 70 or 80 column screen display and allows up to 9 lines of information per entry. Entries are saved under a TAB name - there are 48, 24 alphabetic and 24 user defined. Each set of TAB entries is saved in its own text file. TAB files may be sorted on any field, left or right hand sort, and the sorted file may replace the original.

**Pluses:** The documentation is very good and the program is very easy to use, especially for a novice. For names, addresses and similar short entry type of information, the program is very good. It has flexible printouts and entries can be easily replicated into other tab files for cross-reference ability without retyping.

**Minuses:** The program has a limited scope of usage. The field format is preset and unchangeable. There is no searching ability to find a particular record, other than flipping through records one at a time.

**Skill level required:** No previous knowledge necessary.

**Reviewer:** Phil Daley

Product Name: **64 Doctor**  
Equipment  
Req'd: Commodore 64 and disk drive  
Manufacturer: Computer Software Associates  
44 Oak St.  
Newton Upper Falls, MA 02164  
Author: Eric Berkowitz & David Pollack

**Description:** A diagnostic aid to troubleshoot your C-64 including RAM, keyboard and audio, and associated peripherals - disk drive, printer, cassette, joystick, and video unit. They can be tested individually or in an auto-test mode. Any problems encountered are printed on the screen.

**Pluses:** The disk and short instruction manual are a lesson in user friendliness. The program uses an interesting graphic presentation to simplify use. Problems are clearly spelled out with a suggestion to take the offending equipment to a repairman.

**Minuses:** If the C-64 is not working or the disk drive won't load a program, you'll never get this program in to determine what's wrong. Saving a copy on a cassette would probably be a good idea.

**Skill level required:** No prior knowledge necessary.

**Reviewer:** Phil Daley

# OS9 APPLICATION SOFTWARE

ACCOUNTS  
PAYABLE  
**\$349**

GENERAL  
LEDGER  
with  
CASH

PAYROLL  
**\$549**

ACCOUNTS  
RECEIVABLE  
**\$349**

JOURNAL  
**\$449**

SMALL  
BUSINESS  
INVENTORY  
**\$349**

COMPLETE DOCUMENTATION \$19.95

OS9 & BASIC 09 ARE TRADEMARK OF  
MICROWARE, INC. & MOTOROLA CORP.

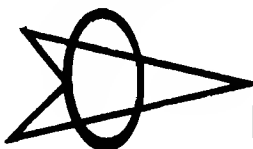

**SPECIALTY  
ELECTRONICS**

(405) 233-5564  
2110 W. WILLOW - ENID, OK 73701

Product Name: **The Computer Mechanic**  
Equipment  
Req'd: Commodore 64 and Disk Drive  
Manufacturer: Softsync, Inc.  
14 East 34th St.  
New York, NY 10016

**Description:** This program is a computerized automotive instruction and diagnostic tool. It teaches an auto novice about possible causes of various problems and the recommended time intervals between certain checks and maintenance. Covered topics include oil change, brake job, transmission check, tune up and tire rotation. The program will also save a file on up to 100 different vehicles, to help keep track of the last performed maintenance dates.

**Pluses:** The program is extremely easy to use and requires almost no instruction manual. There are interesting graphics of the various parts of a car.

**Minuses:** If you know almost anything about cars, this program is too simple to be of any value. The save the date section of maintenance might be useful if the program looked to see when maintenance is due, but it doesn't. You have to look at the individual records and then write them down while you look at the maintenance interval section to see if any is due. No printer output.

**Skill level required:** None

**Reviewer:** Phil Daley

# A Relocatable Step/Trace

by Chester H. Page

Step & Trace program can be moved easily to any part of your program.

## Listing 1

```

0022      W EQU $22
002F      LGTH EQU $2F
0033      PRMP EQU $33
0034      YSAV EQU $34
003A      PCL EQU $3A
003B      PCH EQU $3B
003C      XQT EQU $3C
0048      STAT EQU $48
0100      STCK EQU $100
0670      UW EQU $670
0674      TW EQU $674
C000      KBRD EQU $C000
F882      INSD EQU $F882
F8D0      DISA EQU $F8D0
F954      ADJ2 EQU $F954
F956      ADJ3 EQU $F956
FAD7      REGD EQU $FAD7
FADA      RGDS EQU $FADA
FC22      VTAB EQU $FC22
FD67      GETL EQU $FD67
FDED      COUT EQU $FDED
FE00      BL1 EQU $FE00
FE75      A1PC EQU $FE75
FF3A      BELL EQU $FF3A
FF3F      RSTR EQU $FF3F
FF4A      SAVE EQU $FF4A
FFA7      GETN EQU $FFA7
FF58      RTRN EQU $FF58
FFBE      TSUB EQU $FFBE
FFC5      TSB1 EQU $FFC5
FFC7      ZMOD EQU $FFC7
FFCC      CHRT EQU $FFCC
*
*INITIALIZE WINDOW AREAS
*
ORG $7000
OBJ $800
LDA #0
7000 A9 00

```

MICRO on the Apple, Vol. 2, contains a Step and Trace program for the Apple II+; it is an adaptation of the step and trace routines in the old monitor ROM, so has the same problems. The article warns that DOS causes trouble when it changes an output hook, as in the COUT routine, but there is no warning about the other problems I encountered on my first attempt to use the program.

The user program I wanted to trace contained a printing routine of the type:

```

LDX #TEXT
LDY /TEXT
JSR PRINT
PRINT STX PTR
      STY PTR+1
      LDY #0
LOOP  LDA (PTR),Y
      BEQ DONE
      JSR COUT
      INY
      JMP LOOP
DONE  RTS

```

where TEXT is the address of the data: 8D D4 C5 D8 D4 00. This asks to print a carriage return (for a fresh line), the word "TEXT" and to leave on reading the zero byte.

The DOS problem is easily solved by BLOADing STEP/TRACE, then disconnecting DOS by entering PR#0, IN#0.

My first unexpected problem was

```

7002 85 22          STA W
7004 A9 14          LDA #$14
7006 85 23          STA W+1
7008 A9 13          LDA #$13
700A 85 25          STA W+3
700C A9 16          LDA #$16
700E 8D 70 06       STA UW
7011 A9 18          LDA #$18
7013 8D 71 06       STA UW+1
7016 A9 00          LDA #0
7018 8D 72 06       STA UW+2
701B A9 17          LDA #$17
701D 8D 73 06       STA UW+3
*
7020 D8          STRT  CLD
7021 20 3A FF     JSR  BELL
7024 A9 2A        CONT  LDA  #$2A
7026 85 33          STA  PRMP
7028 20 67 FD     JSR  GETL
702B 20 C7 FF     JSR  ZMOD
702E 20 A7 FF     NXTI  JSR  GETN
7031 84 34          STY  YSAV
7033 C9 EC        TRYS  CMP  #$EC
7035 F0 0B          BEQ  ENT2
7037 C9 ED        TRYT  CMP  #$ED
7039 D0 0D          BNE  TRCR
703B AD 00 C0      LDA  KBRD
703E 30 22          BMI  AGIN
7040 C6 34          DEC  YSAV
7042 20 C7 FF     ENT2  JSR  ZMOD
7045 B8            CLV
7046 50 21          BVC  STPZ
7048 C9 C6        TRCR  CMP  #$C6
704A D0 09          BNE  MCMD
704C 20 C5 FF     JSR  TSB1
704F 20 00 FE     JSR  BL1
7052 B8            CLV
7053 50 CF          BVC  CONT
7055 A0 17        MCMD  LDY  #$17
7057 88           CHRS  DEY
7058 30 C6          BMI  STRT
705A D9 CC FF     CMP  CHRT,Y
705D D0 F8          BNE  CHRS
705F 20 BE FF     JSR  TSUB
7062 A4 34        AGIN  LDY  YSAV
7064 B8            CLV
7065 50 C7          BVC  NXTI
7067 50 B7        RS3   BVC  STRT
7069 20 75 FE     STPZ  JSR  A1PC
706C 20 D0 F8     STEP  JSR  DISA ; DISPLAY INSTRUCTION
706F A2 02          LDX  #2
7071 A9 EA        XQIN  LDA  #$EA
7073 95 3C          STA  XQT,X
7075 CA            DEX
7076 D0 F9          BNE  XQIN
*
*INITIALIZE EXECUTE AREA WITH NOP'S AND RETURN JUMPS
*
7078 20 58 FF     JSR  RTRN
707B B8            CLV
707C 50 0E          BVC  BR
707E 18           BRAN  CLC
707F A0 01          LDY  #1
7081 B1 3A          LDA  (PCL),Y
7083 20 56 F9     JSR  ADJ3
7086 85 3A          STA  PCL
7088 98            TYA
7089 38            SEC
708A B0 6C          BCS  R2 ; JUMP TO PCN2
708C BA           BR    TSX ; LOCATE BRAN AND INSERT JUMP COMMAND

```

caused by the carriage return [8D]. Somehow this gets repetitively tangled with the returns in the disassembly routine, with the result that the screen is scrolled with a complete set of blank lines and the trace program left in an infinite loop of scrolling commands! Removing the 8D uncovered a second problem. In COUT, Y is saved [in YSAV1, \$35] and restored after the actual printing is performed. But each of the intermediate steps is processed by Step-Trace, using COUT to display these steps. The net result is that when the COUT routine in the user program is finished, it always restores Y to 0 and the second letter of text (Y=1) is printed repetitively.

The third problem is that the letters that do get printed overwrite a character in the command display, so that they are not evident. I decided to modify Step-Trace to eliminate these problems.

The first two were cured by examining each command to see if it is "JSR COUT". When this is encountered, the COUT routine is called directly by my trace program so that it will not be traced stepwise. This also eliminated the problem with DOS; DOS no longer needs to be disconnected. The third problem is cured by establishing a split screen; whenever the substitute COUT is to be called, the window parameters being used by the trace program (window top, bottom, horizontal and vertical cursor positions) are saved and replaced by a user set. After a text-character printout, this user set is saved and the trace-program set replaced. With this modification, the TEXT is printed out properly in the two bottom screen lines and all program display is kept above it (with a blank gap between).

All these improvements lengthen the program so that it will no longer fit in the \$300 page. Since it should be useful for tracing a program located anywhere, it should be written in relocatable form so that it can be used by BRUN STEP/TRACE, AX where X is any convenient location that avoids the program to be examined. The internal jumps were converted to relative jumps using CLV followed by BVC and relay points inserted when the jump distances were too large. The

only real problem was figuring out how to convert the routine for installing the jump commands that follow the copied user-program command at \$3C, since the commands to be transferred are themselves internal program jumps (to NBRN and BRAN, for returns from "no-branch" and "branch" operations).

I solved this problem by eliminating these jump instructions from the trace program and installing the NBRN and BRAN addresses directly into the jump commands at \$3F/44. This is done by using a location finding routine at BRAN and again at NBRN.

I first tried doing this with BRAN and NBRN at the beginning of the program so that the self-locating routine wouldn't have to be repeated with every user command, but could be used once as part of the initialization. Unfortunately, some of the monitor subroutines such as GETN in NXTI use some of the memory locations right after \$3C and the initialization gets overwritten. My second try was to move the XQT area from \$3C to \$E0, since this would be interfered with only by HiRes graphics. This worked fine, but then I realized that the \$E0 area is sometimes used for program pointers in non-graphics programs, so that there could be interference. For this reason, I finally put NBRN and BRAN in the XQIN area, where the \$3C region is initialized before each program command.

The final decision to be made concerned the storage of window parameters. Again, zero page is out because of possible interference with user programs. There are nice unused areas available up in DOS, but again there can be interference; I have used many of these locations for data storage in long complex programs that exhaust zero page.

For a trace program at a fixed location the window parameters could be stored within the program, but I was soon convinced that relocatability would be too complicated. My final choice was to dedicate one screen line to this storage. Since I wanted a blank area to separate the trace window from the user window, I put the window parameter storage at the end of one of

```

708D CA          DEX
708E 18          CLC
708F BD 00 01   LDA STCK,X
7092 69 04      ADC #4
7094 85 43      STA XQT+7
7096 E8          INX
7097 BD 00 01   LDA STCK,X
709A 69 00      ADC #0
709C 85 44      STA XQT+8
709E A9 4C      LDA #$4C
70A0 85 3F      STA XQT+3
70A2 85 42      STA XQT+6
70A4 20 58 FF   JSR RTRN
70A7 B8          CLV
70A8 50 0A      BVC NB
70AA 20 4A FF NBRN JSR SAVE ; SAVE USER REGISTERS
70AD 38          SEC
70AE B0 4A      BCS R3 ; JUMP TO PCN3
*
70B0 50 B5      RS2   BVC RS3   RELAY
70B2 50 AE      RA3   BVC AGIN  RELAY
*
70B4 BA        NB    TSX      ; LOCATE NBRN AND INSERT JUMP COMMAND
70B5 CA          DEX
70B6 18          CLC
70B7 BD 00 01   LDA STCK,X
70BA 69 04      ADC #4
70BC 85 40      STA XQT+4
70BE E8          INX
70BF BD 00 01   LDA STCK,X
70C2 69 00      ADC #0
70C4 85 41      STA XQT+5
*
* COPY USER COMMAND TO XEQ AREA
*
70C6 A2 00      LDX #0
70C8 A1 3A      LDA (PCL,X)
70CA F0 3A      BEQ XB1 ; JUMP TO XBRK
70CC A4 2F      LDY LGTH
70CE C9 20      CMP #$20
70D0 F0 38      BEQ CHECK
70D2 C9 60      CMP #$60
70D4 F0 32      BEQ XR1 ; JUMP TO XRTS
70D6 C9 4C      CMP #$4C
70D8 F0 28      BEQ X1
70DA C9 6C      CMP #$6C
70DC F0 26      BEQ XT
70DE C9 40      CMP #$40
70E0 F0 76      BEQ XR1
70E2 29 1F      AND #$1F
70E4 49 14      EOR #$14
70E6 C9 04      CMP #4
70E8 F0 02      BEQ XQ2
70EA B1 3A      XQ1  LDA (PCL),Y
70EC 99 3C 00 XQ2 STA XQT,Y
70EF 88          DEY
70F0 10 F8      BPL XQ1
70F2 20 3F FF   JSR RSTR ; RESTORE USER REGISTERS
70F5 4C 3C 00   JMP XQT
*
70F8 B0 66      R2    BCS PCN2 ; RELAY
70FA B0 66      R3    BCS PCN3 ; RELAY
70FC 50 AC      RN    BVC NBRN ; RELAY
70FE 50 B0      RS1   BVC RS2 ; RELAY TO STRT
7100 50 B0      RA2   BVC RA3 ; RELAY TO AGIN
7102 F0 73      X1    BEQ XJMP ; RELAY
7104 F0 72      XT    BEQ XJAT ; RELAY
7106 F0 45      XB1   BEQ XBRK ; RELAY
7108 F0 52      XR1   BEQ XR1S ; RELAY
*

```

```

710A A0 01 CHECK LDY #1 ;IS COMMAND COUT?
710C B1 3A LDA (PCL),Y
710E C9 ED CMP #$ED
7110 D0 5A BNE XJSR
7112 C8 INY
7113 B1 3A LDA (PCL),Y
7115 C9 FD CMP #$FD
7117 D0 53 BNE XJSR
7119 A2 03 LDX #3 ; USER COMMAND IS COUT
711B B5 22 SVT LDA W,X ; SAVE TRACE WINDOW
711D 9D 74 06 STA TW,X
7120 CA DEX
7121 10 F8 BPL SVT
7123 A2 03 LDX #3
7125 BD 70 06 LDU LDA UW,X ; LOAD USER WINDOW
7128 95 22 STA W,X
712A CA DEX
712B 10 F8 BPL LDU
712D 20 22 FC JSR VTAB ; POSITION CURSOR
7130 20 3F FF JSR RSTR ; RESTORE USER REGISTERS
7133 20 ED FD JSR COUT ; PRINT IN USER AREA
7136 A2 03 LDX #3
7138 B5 22 SVU LDA W,X ; SAVE USER WINDOW
713A 9D 70 06 STA UW,X
713D CA DEX
713E 10 F8 BPL SVU
7140 A2 03 LDX #3
7142 BD 74 06 LDT LDA TW,X ; LOAD TRACE WINDOW
7145 95 22 STA W,X
7147 CA DEX
7148 10 F8 BPL LDT
714A B8 CLV
714B 50 AF BVC RN ; JUMP TO NBRN
714D 20 82 F8 XBRK JSR INSD
7150 20 DA FA JSR RGDS
7153 B8 CLV
7154 50 A8 BVC RS1 ; JUMP TO STRT
7156 50 A8 RA1 BVC RA2 ; RELAY TO AGIN
7158 18 XRTI CLC
7159 68 PLA
715A 85 48 STA STAT
715C 68 XRTS PLA
715D 85 3A STA PCL
715F 68 PLA
7160 85 3B PCN2 STA PCH
7162 A5 2F PCN3 LDA LGTH
7164 20 56 F9 JSR ADJ3
7167 84 3B STY PCH
7169 18 CLC
716A 90 14 BCC NEWP
716C 18 XJSR CLC
716D 20 54 F9 JSR ADJ2
7170 AA TAX
7171 98 TYA
7172 48 PHA
7173 8A TXA
7174 48 PHA
7175 A0 02 LDY #2
7177 18 XJMP CLC
7178 B1 3A XJAT LDA (PCL),Y
717A AA TAX
717B 88 DEY
717C B1 3A LDA (PCL),Y
717E 86 3B STX PCH
7180 85 3A NEWP STA PCL
7182 B0 F3 BCS XJMP
7184 20 D7 FA JSR REGD ; DISPLAY USER REGISTERS
7187 B8 CLV
7188 50 CC BVC RA1 ; JUMP TO AGIN

```

these blank lines. (It shows as 8 inverse characters at the right.)

The final program still suffers from a very slight defect: it will not tolerate PR#1 or a machine loading of CSWL to activate the printer.

To test this Step/Trace program, (1) RUN TEST, enter FF58S CR, then S CR, .... or (2) HOME, enter the TEXT program below, BRUN STEP/TRACE,A12345, enter 300S CR, S CR, .... or 300T CR.

10 REM TEST

```

20 PRINT CHR$(4)
   'BRUN STEP/TRACE':
PRINT 'HELLO'

```

30 END

TEXT

CALL - 151

```

300:A2 18 A0 03 20 07 03 86 06
84 07 A0 00 B1 06 F0 06 20 ED FD
C8 10 F6 00 8D D4 C5 D8 D4 00

```



**At last! . . . A dual 6522 versatile interface adapter (VIA) board for the Commodore-64.**

The 6522 VIA, long the preferred input/output chip for 6502 microcomputers, is now available for the C-64. 6522 programming techniques, covered in many available books, can now be applied to the C-64 for even the most sophisticated real-time control applications. Board allows full use of the IRQ interrupt. When combined with the C-64's memory capacity, it provides an extremely powerful yet cost-effective development system and controller in one package. Includes extensive application notes and programming examples.

Up to four boards can be connected together, providing sixteen 8-bit ports. Order Model 64IF22. \$169 for one, postpaid USA. Each additional \$149.

**Complete reconstructed Assembly Language source code for the C-64's BASIC and KERNAL ROMs, all 16 K!**

Extensively commented and cross-referenced. Far more than a mere "memory map" of useful locations, this book really does tell all. An incredible time-saver in effective C-64 programming and understanding. Order C-64 Source \$29.95, postpaid USA.

**SCHNEDLER SYSTEMS**  
1501 N. Ivanhoe, Dept. M8  
Arlington, VA 22205

Telephone orders/information: (703) 237-4796  
**VISA MASTERCARD**

# Constructing Truly 3-D Mazes

by Dr. Alan Stankiewicz

Get a rat's eye view of the maze corridors as you walk through them.

Just a few months ago, I remember reading an article in this journal concerning the construction of random mazes. The methods described were all quite interesting, however, they all had one thing in common - they were two-dimensional. Today, I will demonstrate a method of generating truly 3-dimensional random mazes on your computer with a minimum of effort and memory. To do this, I will be referring to a program called "Space Maze", written on the unexpanded VIC-20, reprinted here with permission from Victory Software Corporation. To emphasize the fact that not much memory is needed, this particular program will not only generate and store the maze but will actually give you a 3-dimensional rat's-eye view of the corridors as you walk through -all in 3 1/2K of RAM!

To start, you must envision a solid cube which is made up of a large number of smaller cubes, each of which are numbered according to the scheme shown in figure 1. Each of these smaller cubes will correspond to a byte in your computer's memory such that a maze 6 high, 8 wide and 13 deep will take up a block of memory 624 bytes long. This block may be stored anywhere in RAM but in this program, it begins at location 6751 and ends at 7375. The initial construction of this cube is done in line 9 by simply poking the number "2" into each of these bytes, indicating that they now represent a solid section of the maze.

The next major step in the creation of this maze is to wormhole our way through this cube from the front wall to the back wall in a random fashion, thus creating the main pathway. However, before this can be accomplished, we

must further organize the large cube so that as we are drilling our way through, we will have some way of recognizing when we reach an outside wall and when we reach the exit (back wall). To accomplish this, we poke 4's into the bytes which represent the back wall and 3's into the bytes representing the left side, front and top walls (lines 9 and 30). Note that this procedure is not necessary for the right side or bottom wall (the reason will become apparent later).

Now that the limits of the cube are clearly marked, the drilling process may begin. The starting location for the main path in this program is selected to

be 6808 which is the byte (or small block) located one layer down from the top, one layer in from the front and one layer over from the left (this would be block number 58 in figure 1). The number "1" will be poked in this location to show that it is now a "drilled out" byte and the variable "L" is set equal to 6808 (our present location). From here, we choose a random direction to start moving, but before drilling in that direction, we must peek the location directly in front of our drill to make sure it is not an outside wall (designated by a 3). If it is, another direction will have to be chosen. If it is an inside solid portion

Figure 1

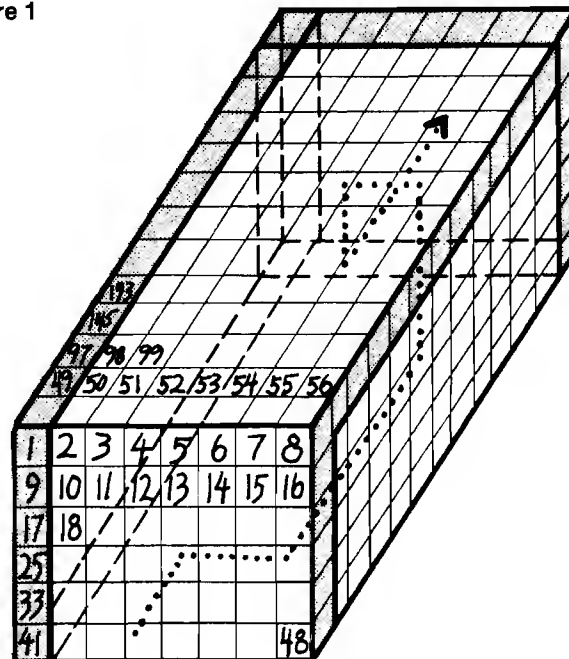

(designated by a 2) then we will proceed to drill out two bytes in that direction by poking 1's there and reassigning "L" equal to the location of the most freshly drilled out byte. The reason for moving two bytes at a time is so there will always be a wall between every corridor. After each drilling, the decision is made whether or not to change directions. For a more complex maze, of course, you would want to change directions more frequently. When you finally peek a "4", you

know that you hit the back wall and your main path is complete, front to back. There is one difficulty which exists with this method, however, and that is the possibility of drilling yourself into an area which is totally surrounded by 3's and/or 1's with no possibility of finding a "2" (an undrilled inside byte) no matter which direction you look. This situation is easily resolved, however, by allowing yourself to backtrack over the main path every so often and as you do this,

to fill up these "dead ends" with 3's (line 58) so you will never go there again. Backtracking can be kept to a minimum by only allowing it to occur, for example, after every 20th direction change.

In addition to controlling the frequency of direction changes, the difficulty level of the maze can also be regulated by setting a minimum length for the main path, that is, if in the drilling process you peek a "4", check the length of the main path (line 55). If it is not yet long enough, then change directions and continue to drill. The length of the main path is continuously monitored in "Space Maze" by adding 2 to the variable "U" every time you drill (line 54). Also don't forget to subtract from U when backtracking.

We now have a cube with a wormhole bored through it from front to back. The next major step, of course, is to create side paths to confuse the mouse. This task is accomplished in exactly the same manner as the main path, only we now start at randomly selected bytes on the main path and continue for variable distances outward. If memory permits, you may even want to differentiate the side paths by poking a "5" into these bytes, thereby creating a method of distinguishing the main path from the side paths during the display of the maze.

This brings us to the final problem of how to display our truly 3-D maze on a 2-D television screen. One technique is to display successive layers of the maze, as if you were able to slice it up with a knife and show one slice at a time (figure 2). Another more dramatic representation is to let the user "walk" through the maze, giving him a 3-dimensional view of the passageways as shown in figures 3, 4 & 5. At first glance, the production of this type of display would seem quite complicated, but in principle, all that is required is to draw a big "X" on the TV screen to represent a long hallway and then fill in the doorways as you scan that particular area of the maze. The detailed mechanics of this process are beyond the scope of this article, however, a BASIC program written fairly efficiently can usually draw up such a picture in 2-3 seconds.

I hope this short discussion has succeeded in arousing some interest in maze-building and I would be very interested to hear from anyone who has been able to generate and/or display a 4-dimensional maze!

Figure 2

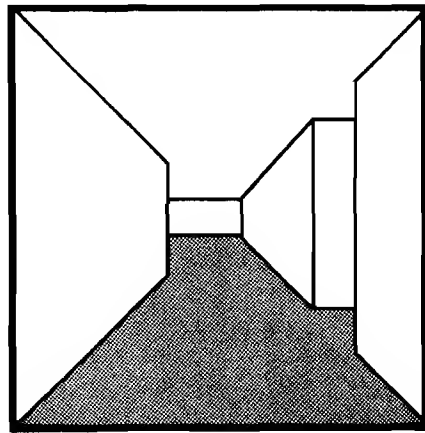
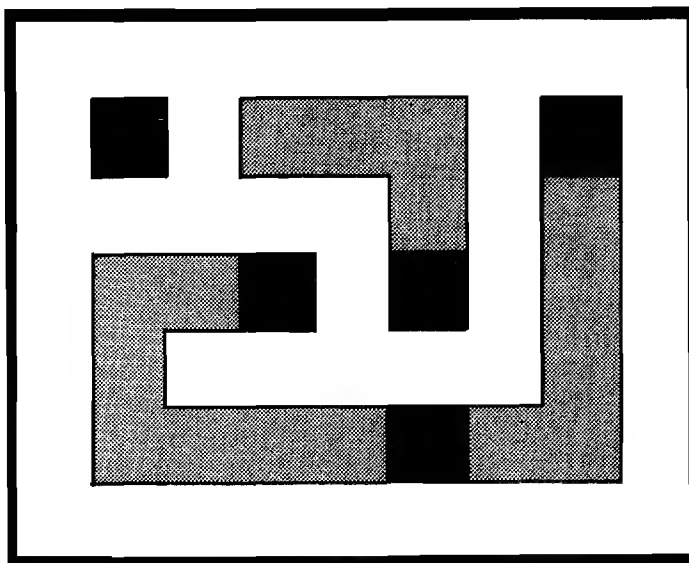

Figure 3



Listing 1

```

Ø POKE 36879,14:POKE 45,47:POKE 46,22:POKE 55,196:POKE 56,22:CLR:
PRINT"{PURPLE}STOP TAPE":GOTO 8
1 I=-N*(M=1)-N*8*(M=2)-N*Y*(M=3):O=I+I:RETURN
2 N=-1-(RND(8)>.5)*2:M=INT(RND(8)*3+1):RETURN
3 GOTO 3ØØ
4 G=255:POKE 84Ø,F AND G:POKE 842,R AND G:POKE 843,D AND G:
POKE 841,-D AND G:POKE 844,-R AND G
5 POKE 1,L/256:POKE Ø,L-PEEK(1)*256:PRINT"{CLEAR}":
POKE 7713,PEEK(C+6634):POKE 36876,248:SYS 7448
6 POKE 36878,..:POKE L,Z:GOTO 97
8 WAIT 37151,64:A=7375:Y=48:B=6751:INPUT"LEVEL(Ø-9)";V=V-.Ø13*V+.3:
J=RND(-TI):PRINT"WORKING;
9 TI$="ØØØØØØ":L=68Ø8:FOR J=B TO A:POKE J,2:NEXT:FOR J=7327 TO A:
POKE J,4:NEXT:FOR J=B TO 6799:POKE J,3:NEXT
3Ø FOR J=Ø TO 12:FOR K=B+J*Y TO B+8+J*Y:POKE K,3:NEXT:
FOR K=B+J*Y TO 6791+J*Y STEP 8:POKE K,3:NEXT:NEXT:POKE L,1
41 GOSUB 2
42 X=X+1:GOSUB 1:IF RND(8)<V THEN 41
54 G=PEEK(L+I):IF PEEK(L+Ø)=2 AND G-3 THEN POKE L+I,1:L=L+Ø:POKE L,1:
U=U+2:GOTO 42
55 IF G=4 THEN IF U>(V-.3)*288 THEN POKE L+I,5:
PRINT U"STEPS TO EXIT":GOTO 66
58 IF G=1 AND INT(X/9)=X/9 THEN POKE L,2:POKE L+I,3:L=L+Ø:U=U-2:
IF TI$B THEN U=Ø:GOTO 9
6Ø GOTO 41
66 FOR J=1 TO (V-.3)*677
68 L=B-1+INT(RND(8)*4+1)*2+INT(RND(8)*3+1)*16+INT(RND(8)*6+1)*96-56
7Ø IF PEEK(L)-1 THEN 68
72 FOR K=1 TO 6:GOSUB 1:IF RND(8)<.3 THEN 82
76 G=PEEK(L+I):
IF PEEK(L+Ø)=2 THEN IF G-3 THEN IF G-5 THEN POKE L+I,1:L=L+Ø:
POKE L,1:NEXT:GOTO 86
82 GOSUB 2:NEXT
86 NEXT:FOR J=B TO A:IF PEEK(J)>2 AND PEEK(J)<5 THEN POKE J,2
95 NEXT:F=1:R=-8:D=-Y:M=37151:N=M+1:X=M+3:E=1:O=197:B=B+8:L=68Ø8:
PRINT"{CLEAR}":POKE 36869,255:GOTO 3
97 WAIT 0,64:G=PEEK(M):IF G-94 AND G-126 THEN 97
98 POKE X,127:IF PEEK(N)-247 THEN 98
115 POKE X,127:IF PEEK(N)=119 THEN 2ØØ
12Ø POKE X,255:G=PEEK(M):IF G=122 THEN J=PEEK(L+F):
IF J-2 AND J-5 THEN L=L+F:GOTO 3
125 IF G=118 THEN J=PEEK(L-F):IF J-2 AND J-5 THEN L=L-F:GOTO 3
13Ø J=R:IF G=11Ø THEN R=F:F=-J:GOTO 3
135 IF G=78 THEN R=-D:D=J:GOTO 3
14Ø J=F:IF G=86 THEN F=-D:D=J:GOTO 3
145 IF G=9Ø THEN F=D:D=-J:GOTO 3
15Ø G=PEEK(Ø):IF G=52 AND B>6766 THEN B=B-8:GOTO 3
155 IF G=12 AND B<6784 THEN B=B+8:GOTO 3
16Ø IF G=8 THEN E=-E:PRINT"{CLEAR}":GOTO 3
19Ø GOTO 115
2ØØ POKE X,255:IF PEEK(M)=94 THEN J=D:D=-R:R=J:GOTO 3
21Ø J=R:R=-F:F=J
3ØØ J=ABS(F):K=ABS(D):
C=((1-(J>1)-(J>8))*SGN(F)+3)*7+(1-(K$1)-(K>8))*SGN(-D)+3
31Ø POKE 834,PEEK(6634+C):Z=PEEK(L):POKE L,9:IF E-1 THEN 4
32Ø J=INT(B/256):POKE 1,B-J*256:POKE 2,J:SYS 7376:GOTO 6

```

Editor's Note: As a service to MICRO  
 readers, the creators of this program  
 will make it available on cassette.  
 Send \$3.00 to:  
 Victory Software Corporation  
 1410 Russell Road  
 Paoli, PA 19301

# FLOPPY DISKS SALE \*\$1.19 ea.

## Economy Model or Cadillac Quality

LORAN CERTIFIED PERSONAL  
COMPUTER DISK

*We have the lowest prices!* LORAN CERTIFIED PERSONAL  
COMPUTER DISK

### \*ECONOMY DISKS

Good quality 5 1/4" single sided single density with hub rings.

Bulk Pac	100 Qty.	\$1.19 ea.	Total Price	\$119.00
	10 Qty.	1.39 ea.	Total Price	13.90

### CADILLAC QUALITY (double density)

- Each disk certified
- Free replacement lifetime warranty
- Automatic dust remover

For those who want cadillac quality we have the Loran Floppy Disk. Used by professionals because they can rely on Loran Disks to store important data and programs without fear of loss! Each Loran disk is 100% certified (an exclusive process) plus each disk carries an exclusive **FREE REPLACEMENT LIFETIME WARRANTY**. With Loran disks you can have the peace of mind without the frustration of program loss after hours spent in program development.

### 100% CERTIFICATION TEST

Some floppy disk manufacturers only sample test on a batch basis the disks they sell, and then claim they are certified. Each Loran disk is individually checked so you will never experience data or program loss during your lifetime!

### FREE REPLACEMENT LIFETIME WARRANTY

We are so sure of Loran Disks that we give you a free replacement warranty against failure to perform due to faulty materials or workmanship for as long as you own your Loran disk.

### AUTOMATIC DUST REMOVER

Just like a record needle, disk drive heads must travel hundreds of miles over disk surfaces. Unlike other floppy disks the Loran smooth surface finish saves disk drive head wear during the life of the disk. (A rough surface will grind your disk drive head like sandpaper). The lint free automatic **CLEANING LINER** makes sure the disk-killers (dust & dirt) are being constantly cleaned while the disk is being operated. **PLUS** the Loran Disk has the highest probability rate of any other disk in the industry for storing and retaining data without loss for the life of the disk.

### *Loran is definitely the Cadillac disk in the world*

Just to prove it even further, we are offering these super **LOW** INTRODUCTORY PRICES

List \$4.99 ea. **INTRODUCTORY SALE PRICE \$2.99 ea.** (Box of 10 only) Total price \$29.90

**\$3.33 ea. (3 quantity) Total price \$9.99**

All LORAN disks come with hub rings and sleeves in an attractive package.

## DISK DRIVE CLEANER \$19.95

Everyone needs a disk drive doctor

### FACTS

- 60% of all drive downtime is directly related to poorly maintained drives.
- Drives should be cleaned each week regardless of use.
- Drives are sensitive to smoke, dust and all micro particles.
- Systematic operator performed maintenance is the best way of ensuring error free use of your computer system.

The Cheetah disk drive cleaner can be used with single or double sided 5 1/4" disk drives. The Cheetah is an easy to use fast method of maintaining efficient floppy diskette drive operation.

The Cheetah cleaner comes with 2 disks and is packed in a protective plastic folder to prevent contamination.

List \$29.95 / Sale \$19.95 \* **Coupon \$16.95.**

Add \$3.00 for shipping, handling and insurance. Illinois residents please add 6% tax. Add \$6.00 for CANADA, PUERTO RICO, HAWAII, ALASKA, APO-FPO orders. Canadian orders must be in U.S. dollars. WE DO NOT EXPORT TO OTHER COUNTRIES.

Enclose Cashiers Check, Money Order or Personal Check. Allow 14 days for delivery. 2 to 7 days for phone orders. 1 day express mail!

VISA — MASTER CARD — C.O.D.

No C.O.D. to Canada, APO-FPO.

**PROTECTO**  
**ENTERPRIZES** WE LOVE OUR CUSTOMERS.

BOX 550, BARRINGTON, ILLINOIS 60010  
Phone 312/382-5244 to order

# BIG FOUR

NEW 128K —MEGA BYTE DUAL DISK DRIVE—80 COLUMN

# COMPUTER SYSTEM SALE!

HOME • BUSINESS • WORD PROCESSING



**\$895<sup>00</sup>**  
(if ordered before 10/1/84)

List Price \$3717.95

LOOK AT ALL YOU GET FOR ONLY \$895.

- |  |                   |
|--|-------------------|
|  | <b>LIST PRICE</b> |
| • B128 COMMODORE 128K 80 COLUMN COMPUTER             | \$ 995 00         |
| • 8050 DUAL DISK DRIVE (over 1 million bytes)        | 1795.00           |
| ★ 4023 · 100 CPS · 80 COLUMN BIDIRECTIONAL PRINTER   | 499 00            |
| • 12" HI RESOLUTION 80 COLUMN GREEN OR AMBER MONITOR | 249 00            |
| • BOX OF 10 LORAN LIFETIME GUARANTEED DISKS          | 49 95             |
| • 1100 SHEETS FANFOLD PAPER                          | 19 95             |
| • ALL CABLES NEEDED FOR INTERFACING                  | 102 05            |

TOTAL LIST PRICE **\$ 3717.95**



Printer replacement options (replace the 4023 with the following at these sale prices)

	LIST	SALE
★ Olympia Executive Letter Quality Serial Printer	\$ 699 00	<b>\$ 399.00</b>
★ Comstar Hi-Speed 160 CPS 15½" Serial-Business Printer	\$ 779 00	<b>\$ 499.00</b>
★ Telecommunications Deluxe Modem Package	\$ 199.00	<b>\$ 139.00</b>

Plus You Can Order These Business Programs At Sale Prices

	LIST	SALE		LIST	SALE
Professional 80 Column Word Processor	\$149 95	<b>\$99.00</b>	Payroll Inventory	\$149 95	<b>\$99.00</b>
Professional Data Base	149 95	<b>99.00</b>	General Ledger	149 95	<b>99.00</b>
Accounts Receivable	149 95	<b>99.00</b>	Financial Spread Sheet	149 95	<b>99.00</b>
Accounts Payable	149 95	<b>99.00</b>	Program Generator	149 95	<b>99.00</b>

**15 DAY FREE TRIAL** We give you 15 days to try out this SUPER SYSTEM PACKAGE!! If it doesn't meet your expectations, just send it back to us prepaid and we will refund your purchase price!!

**90 DAY IMMEDIATE REPLACEMENT WARRANTY** If any of the SUPER SYSTEM PACKAGE equipment or programs fail due to faulty workmanship or material we will replace it IMMEDIATELY at no charge!!

Add \$50.00 for shipping and handling!!  
**\$100.00 for Canada, Puerto Rico, Hawaii orders.**  
 WE DO NOT EXPORT TO OTHER COUNTRIES.  
 Enclose Cashiers Check, Money Order or Personal Check. Allow 14 days for delivery, 2 to 7 days for phone orders, 1 day express mail! Canada orders must be in U.S. dollars. We accept Visa and MasterCard. We ship C.O.D. to U.S. addresses only

**PROTECTO ENTERPRISES** (WE LOVE OUR CUSTOMERS)  
 BOX 550, BARRINGTON, ILLINOIS 60010  
 Phone 312/382-5244 to order

# 80 COLUMN PRINTER SALE—\$149.00\*

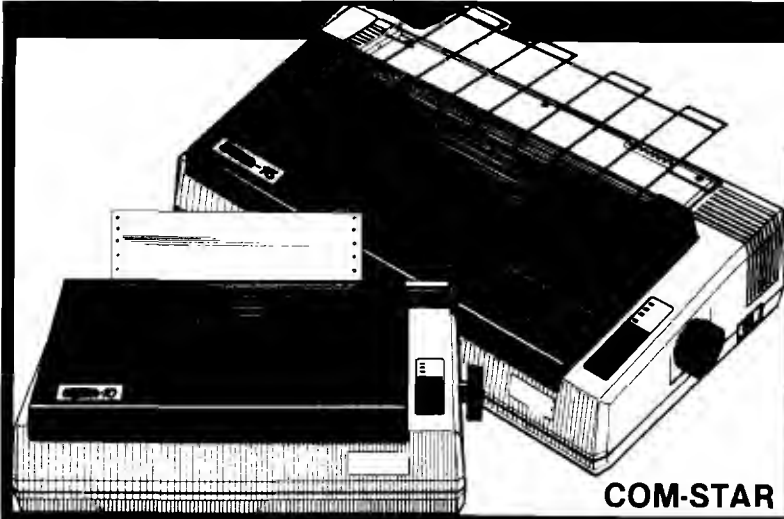

## COM-STAR T/F

Tractor  
Friction  
Printer

only \$ **179\*\***

**• 15 Day Free Trial - 180 Day Immediate Replacement Warranty**

- Lowest Priced, Best Quality, Tractor-Friction Printers in the U.S.A.
- Fast 80-120-160 Characters Per Second • 40, 46, 66, 80, 96, 132 Characters Per Line Spacing
- Word Processing • Print Labels, Letters, Graphs and Tables • List Your Programs
- Print Out Data from Modem Services • "The Most Important Accessory for Your Computer"

### \*STX-80 COLUMN PRINTER—\$149.00

Prints full 80 columns. Super silent operation, 60 CPS, prints Hi-resolution graphics and block graphics, expanded character set, exceptionally clear characters, fantastic print quality, uses inexpensive thermal paper! Best thermal printer in the U.S.A.! (Centronics Parallel Interface).

### \*\*DELUXE COMSTAR T/F 80 CPS PRINTER—\$179.00

The COMSTAR T/F (Tractor Friction) PRINTER is exceptionally versatile. It prints 8½" x 11" standard size single sheet stationary or continuous feed computer paper. Bi-directional, impact dot matrix, 80 CPS, 224 characters. (Centronics Parallel Interface).

### Premium Quality—120 CPS COMSTAR T/F SUPER-10X PRINTER—\$289.00

COMSTAR T/F (Tractor Friction) SUPER-10X PRINTER gives you all the features of the COMSTAR T/F PRINTER plus a 10" carriage, 120 CPS, 9 x 9 dot matrix with double strike capability for 18 x 18 dot matrix (near letter quality), high resolution bit image (120 x 144 dot matrix), underlining, back spacing, left and right margin settings, true lower decenders with super and subscripts, prints standard, italic, block graphics

and special characters, plus 2K of user definable characters! The COMSTAR T/F SUPER-10X PRINTER was Rated No. 1 by "Popular Science Magazine." It gives you print quality and features found on printers costing twice as much!! (Centronics Parallel Interface) (Better than Epson FX 80).

### Premium Quality—120 CPS COMSTAR T/F SUPER-15½" PRINTER—\$379.00

COMSTAR T/F SUPER 15½" PRINTER has all the features of the COMSTAR T/F SUPER-10X PRINTER plus a 15½" carriage and more powerful electronics components to handle large ledger business forms! (Better than Epson FX 100).

### Superior Quality SUPER HIGH SPEED—160 CPS COMSTAR T/F 10" PRINTER—\$399.00

SUPER HIGH SPEED COMSTAR T/F (Tractor Friction) PRINTER has all the features of the COMSTAR SUPER-10X PRINTER plus SUPER HIGH SPEED PRINTING—160 CPS, 100% duty cycle, 8K buffer, diverse character fonts, special symbols and true decenders, vertical and horizontal tabs. RED HOT BUSINESS PRINTER at an unbelievable low price!! (Serial or Centronics Parallel Interface)

### Superior Quality SUPER HIGH SPEED—160 CPS COMSTAR T/F 15½" PRINTER—\$529.00

SUPER HIGH SPEED COMSTAR T/F 15½" PRINTER has all the features of the SUPER HIGH SPEED COMSTAR T/F 10" PRINTER plus a 15½" carriage and more powerful electronics to handle larger ledger business forms! Exclusive bottom paper feed!!

### PARALLEL INTERFACES For VIC-20 and COM-64—\$69.00 For Apple Computers—\$79.00

NOTE: Other printer interfaces are available at computer stores!

### Double Immediate Replacement Warranty

We have doubled the normal 90 day warranty to 180 days. Therefore if your printer fails within "180 days" from the date of purchase you simply send your printer to us via United Parcel Service, prepaid. We will IMMEDIATELY send you a replacement printer at no charge, prepaid. This warranty, once again, proves that WE LOVE OUR CUSTOMERS!

Add \$17.50 for shipping, handling and insurance. WE DO NOT EXPORT TO OTHER COUNTRIES EXCEPT CANADA.  
Enclose Cashiers Check, Money Order or Personal Check. Allow 14 days for delivery, 2 to 7 days for phone orders, 1 day express mail!! Canada orders must be in U.S. dollars. VISA — MASTER CARD ACCEPTED. We ship C.O.D.

**PROTECTO ENTERPRIZES** (WE LOVE OUR CUSTOMERS)  
BOX 550, BARRINGTON, ILLINOIS 60010  
Phone 312/382-5244 to order

SUPER-10" **ABCDEFGHIJKLMN OPQRSTUVWXYZ**  
**ABCDEFGHIJKLMN OPQRSTUVWXYZ 1234567890**

# Olympia EXECUTIVE LETTER QUALITY "DAISY WHEEL PRINTERS"

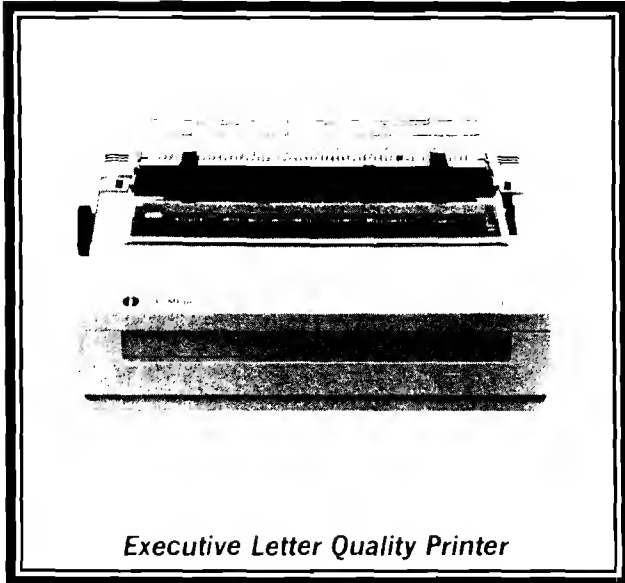

*Executive Letter Quality Printer*

## World's Finest Computer Printer

List Price \$699      **SALE \$399**

- Daisywheel printer, bidirectional with special print enhancements.
- Print speed up to 20 characters per second.
- 10, 12, and 15 characters per inch.
- 256 character print buffer.
- 14.4" forms width.
- Print line width: 115, 138, and 172 characters.
- Serial RS-232-C and parallel Centronics interface ports built-in.
- Built-in bidirectional forms tractor.
- Operating status control panel.

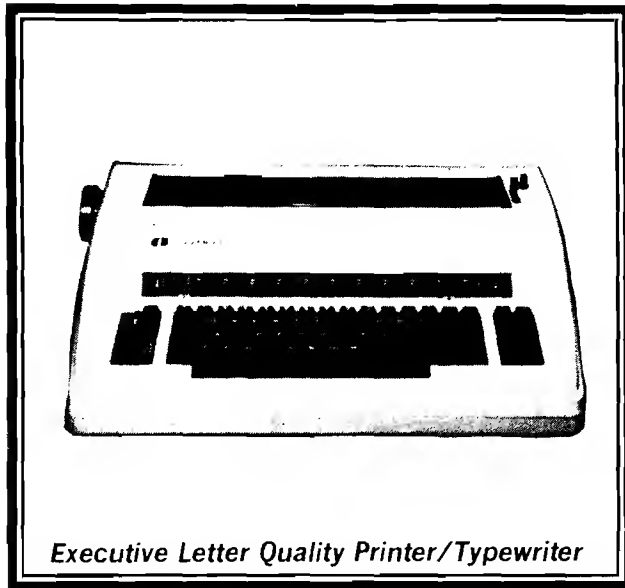

*Executive Letter Quality Printer/Typewriter*

## World's Finest "Combination" Printer/Typewriter

List Price \$799      **SALE \$489**

- Superb computer printer combined with world's finest electronic typewriter!
- Better than IBM selectric — used by world's largest corporations!
- Two machines in one — just a flick of the switch!
- Superb letter quality correspondence — home, office, word processing!
- Extra large carriage — allows 14-1/8" paper usage!
- Drop in cassette ribbon — express lift off correction or eraser up to 46 characters!
- Precision daisy wheel printing — many type styles!
- Pitch selector — 10, 12, 15 CPS, Automatic relocate key!
- Automatic margin control and setting! Key in buffer!
- Electronic reliability, built in diagnostic test!
- Centronics parallel interface built-in

## 15 Day Free Trial - 90 Day Immediate Replacement Warranty

COM 64 — VIC-20 INTERFACE	\$59.00
APPLE INTERFACE	\$79.00

Add \$17.50 for shipping, handling and insurance. Illinois residents please add 6% tax. Add \$35.00 for CANADA, PUERTO RICO, HAWAII, ALASKA, APA-FPO orders. Canadian orders must be in U.S. dollars. WE DO NOT EXPORT TO OTHER COUNTRIES.

Enclose Cashiers Check, Money Order or Personal Check. Allow 14 days delivery, 2 to 7 days for phone orders, 1 day express mail!

VISA — MASTERCARD — C.O.D.

No C.O.D. to Canada, APO-FPO

**PROTECTO**  
**ENTERPRIZES** (WE LOVE OUR CUSTOMERS)  
 BOX 550, BARRINGTON, ILLINOIS 60010  
 Phone 312/382-5244 to order

# Commodore - 64

# WORD PROCESSING BREAKTHROUGH!

## SCRIPT-64 EXECUTIVE WORD PROCESSOR

(80 Columns in Color)

40 or 80 columns in color or black and white; turns your computer into a Business Machine!

Rated best by COMMODORE. This is the finest word processor available. Features include line and paragraph insertion/deletion, indentation, right and left justification, titles, page numbering, characters per inch, etc. All features are easy to use and understand. With tabs, etc. SCRIPT-64 even includes a 250 word dictionary/spelling checker to make sure your spelling is correct. The dictionary is user customizable to any technical words you may use. Furthermore, all paragraphs can be printed in writing and everyday letters are a snap. To top things off, there is a 100 page manual and help screens to make learning how to use SCRIPT-64 a snap. This word processor is so complete we can't think of anything it doesn't have. When combined with the complete database you have a powerful mailmerge and label program that lets you customize any mailing list with personalized letters. List \$99.95. **Sale \$59.00.** \*Coupon Price \$49.00. (Disk only.)

## SCRIPT-64 20,000 WORD DICTIONARY

Allows you to check spelling on 20,000 most often misspelled words! List \$29.95. **Sale \$19.95.** \*Coupon Price \$12.50 (Disk only.)

## SCRIPT-64 COMPLETE DATABASE

(Plus Mail Merge and Labels)

This powerful DATABASE is user friendly and makes any information easy to store and retrieve. The user defines the fields and then can add, change, delete, and search for any category wanted! Must be used with the SCRIPT-64 EXECUTIVE WORD PROCESSOR. When combined with the Executive Word Processor you can search out any category (zip codes, even hair color, etc.) and print super personalized letters! 600 names can be sorted and formulated on each disk in any order or category! Will handle any size mailing list by changing or adding disks! List \$69.00. **Sale \$39.00.** \*Coupon Price \$29.00.

• LOWEST PRICES • 15 DAY FREE TRIAL • 90 DAY FREE REPLACEMENT WARRANTY  
• BEST SERVICE IN U.S.A. • ONE DAY EXPRESS MAIL • OVER 500 PROGRAMS • FREE CATALOGS

WE SHIP C.O.D. HONOR VISA AND MASTER CHARGE  
ADD \$3.00 SHIPPING FOR C.O.D. ADD \$2.00 MORE  
SPECIAL SERVICES:  
One Day — Express Mail add \$10.00

**PROTECTO**  
**ENTERPRIZES** (WE LOVE OUR CUSTOMERS)  
BOX 550, BARRINGTON, ILLINOIS 60010  
Phone 312/382-5244 to order



# SANYO MONITOR SALE!!



9" Data Monitor

- 80 Columns x 24 lines
- Green text display
- Easy to read - no eye strain
- Up front brightness control
- High resolution graphics
- Quick start - no preheating
- Regulated power supply
- Attractive metal cabinet
- UL and FCC approved

- **15 Day Free Trial - 90 Day Immediate Replacement Warranty**

9" Screen - Green Text Display	\$ 69.00
12" Screen - Green Text Display (anti-reflective screen)	\$ 99.00
12" Screen - Amber Text Display (anti-reflective screen)	\$ 99.00
12" Screen-Super 1000 Line Amber Text Display	\$119.00
14" Screen - Color Monitor (High Resolution)	\$239.00

### Display Monitors From Sanyo

With the need for computing power growing every day, Sanyo has stepped in to meet the demand with a whole new line of low cost, high quality data monitors. Designed for commercial and personal computer use. All models come with an array of features, including up-front brightness and contrast controls. The capacity 5 x 7 dot characters as the input is 24 lines of characters with up to 80 characters per line.

Equally important, all are built with Sanyo's commitment to technological excellence. In the world of Audio/Video, Sanyo is synonymous with reliability and performance. And Sanyo quality is reflected in our reputation. Unlike some suppliers, Sanyo designs, manufactures and tests virtually all the parts that go into our products, from cameras to stereos. That's an assurance not everybody can give you!



- LOWEST PRICES • 15 DAY FREE TRIAL • 90 DAY FREE REPLACEMENT WARRANTY
- BEST SERVICE IN U.S.A. • ONE DAY EXPRESS MAIL • OVER 500 PROGRAMS • FREE CATALOGS

Add \$10.00 for shipping, handling and insurance. Illinois residents please add 8% tax. Add \$20.00 for CANADA, PUERTO RICO, HAWAII orders. WE DO NOT EXPORT TO OTHER COUNTRIES.

Enclose Cashiers Check, Money Order or Personal Check. Allow 14 days for delivery, 2 to 7 days for phone orders, 1 day express mail! Canada orders must be in U.S. dollars. Visa - MasterCard - C.O.D.

**PROTECTO ENTERPRISES** (WE LOVE OUR CUSTOMERS)  
 BOX 550, BARRINGTON, ILLINOIS 60010  
 Phone 312/382-5244 to order

## \* Graphic Print for C-64 \*

### Part 2

by Michael J. Keryan

---

#### Create full-page graphic printouts interfacing with major commercial software.

---

Last month we saw how to add a fast machine language routine to dump a graphic screen to most popular non-Commodore printers. This month we add another machine language program and a BASIC program that can load graphic files from a number of popular graphic programs, display them, and dump them to a printer.

Last time, a general purpose graphic dump program was described [GDUMP]. This program will give HiRes or MULTicolor graphic dumps in various dot patterns — the density of the dot pattern is proportional to the darkness of the actual colors used in the picture. Sixteen different patterns are used so that even two colors that look identical on a black and white monitor or TV can be distinguished on the printout. The printouts are about 7x9 inches and take from two to two and a half minutes, depending on your printer speed. Printers supported are NEC 8023, PROWRITER, C. ITOH 8510, EPSON MX-80, FX-80, GEMINI, and any other printer that emulates graphic modes of these printers.

Now we have a program that will print graphics. But what are we going to print? Well, it would be nice if we could use this program to print all our neat pictures, graphs, etc. that we developed with those graphic aid and drawing programs that we paid anywhere from \$20 to \$75 for. You remember, the ones that didn't come with a screen dump program or the ones that took three minutes to produce a picture small enough to stick in your wallet? To print these, we'll first have to transform their graphs to memory areas we can easily get to. We'll need a machine language program to do this because we'll want to move between 8K and 10K of memory. But first we need a BASIC program that makes things a lot simpler.

A small BASIC program [see Listing 1] ties everything together. The first thing this program does is load the machine language programs GDUMP [from last time] and GMOVE [Listing 2]. These were combined into one program "GDUMP+MOVE". Then a jump is made to line 2000 which changes the screen colors and displays a menu. You are given the choice of dumping graphics made from SIMONS' BASIC, ULTRABASIC-64, DOODLE, KOALAPainter, or SLIDESHOW. A sixth option allows SLIDESHOW graphics to be inverted.

If the picture is stored on a disk [options 2-6], you are instructed to put in the disk containing the picture and type in the name of the file. For DOODLE files, include the DD as part of the file name as listed on the directory. For KOALA files, include the PIC part, such as "PIC H CASTLE", but don't worry about the initial reverse field character that shows up in the directory. All file names can be shortened, but don't use the \* wildcard; for example "PIC H" will work fine.

The picture is loaded into the same memory areas that these other programs use. Our BASIC program then jumps to line 1050. The graphic screen is reconfigured by a SYS to GMOVE. The workings of GMOVE is described later. Printer specific controls are set up [lines 1050-1100], then the keyboard is polled. If you hit P, you will get a printout. Any other key will reset the screen and end the program with no printed output.

#### SIMONS' BASIC

SIMONS' BASIC is a new package of BASIC extensions, distributed by Commodore. It comes in a plug-in

cartridge form and reduces the size of BASIC workspace by 8K bytes. With SIMONS' BASIC, you get 114 more BASIC commands in 12 general categories. This is a super package and is a steal at \$20. A drawback is that it uses the \$CXXX area of RAM, making most of your machine language programs incompatible. However, this package contains so much utility that you may not need other ML programs.

With SIMONS' BASIC, you can make pictures, graphs, etc. in HiRes or MULTicolor modes. You are given quite a few graphic commands for drawing lines, circles, blocks, adding text, etc. It has a COPY command that will dump the graphic screen to a printer in Commodore 1525 format.

Although the copy command is handy, it has a few undesirable features. It is small {4 x 2 3/4 on my printer} and slow {3 minutes}. SIMONS' BASIC allows color redefinition, but only 3 colors can be specified at any time. With COPY, colors 1 and 2 come out as half-tone [vertical lines], while color 3 comes out solid black. Your highly colored pictures may look great on the screen, but the printouts may lack a little contrast between colors.

SIMONS' BASIC places the 8K bit map memory in hidden RAM, under the KERNAL at \$E000-\$FFFF. The 1K screen memory is placed at \$C000 [normally found at \$0400]. The routine GDSIMN [see Listing 2] switches out the ROM, allowing you to access the 8K bit map data, transfers the memory to \$2000-\$3FFF, and then switches the ROM back in. It also places \$C0 into the screen pointer. Since SIMONS' BASIC contains no command to dump a graphic screen to disk, you will have to print the screen while it is displayed. By running the program in Listing 1, you can create a 7 line BASIC program for SIMONS' BASIC. Append your graphic program to this one with the SIMONS' BASIC MERGE command. Then when you want the graphic screen dumped to the printer, just include the line GOTO 1. This short program uses only one variable, A. Make sure you don't use A in the body of your program

#### ULTRABASIC-64

ULTRABASIC-64 is a package of 50 extra BASIC commands, made by Abacus Software. The graphic

commands are quite similar to those of SIMONS' BASIC. A graphic screen dump using the HARD command is also similar: it is fairly slow, small, and does not give accurate color shading renditions. With ULTRABASIC-64 dumps, you get 3 different shade densities for colors defined as 1, 2, and 3. But the darkness is a function of the color number [1, 2, 3] which is not related to the actual darkness of that color.

With ULTRABASIC-64, you can save a graphic screen to disk with the DUMP command or by pressing function key F2. This file can later be read in, reconfigured, and printed with all the attributes of GDUMP. GDULTR in Listing 2 first switches out the ROMS, moves the 8K bit map area of memory located at \$A000-\$BFFF to \$2000-\$3FFF, then re-enables the ROMS. The program then relocates the 1K screen memory starting at \$8400 to \$0400, and the 1K color memory starting at \$8800 to \$D800. The border color is moved from \$83E0 to \$D020, and the background color from \$83E1 to \$D021. The screen is then configured for bit-mapped graphics and \$83D6 is transferred to \$D016 to enable either HiRes or MULTI modes.

## DOODLE

DOODLE is a very extensive drawing program, by Omni Unlimited. Although somewhat difficult to learn due to the many options and menus, you can create quite outstanding drawings with a joystick. Because DOODLE uses the HiRes mode, you can get lines that are only one dot wide; most other color drawing packages allow only two-dot resolution due to the use of MULTI mode. In any 8x8 square of dots, you can display any two colors: one for the dots and another for the background. However, the colors in any other 8x8 square block can be completely different. Of course, DOODLE handles all this for you; you just draw the pictures.

DOODLE provides a printer setup program for non-Commodore printers and a graphic dump program which is better than most other graphic packages attempts. It allows two sizes and is fast. The printer dumps have one fault, however. All dots are printed as black and all background is printed as white — no matter what colors were used for the dots and background. Check out the Middle Earth demo that

is on the DOODLE disk. The white clouds against the blue sky are printed as black clouds on a white sky.

DOODLE contains a routine to save a picture to disk. It creates a file with DD as the first two characters of the file name. With the programs provided in Listings 1 and 2, you can read in the file, reconfigure and display it, and print it with GDUMP. GDDOOD in Listing 2 moves the 8K bit map area from \$6000-\$7FFF to \$2000-\$3FFF, and the 1K screen area from \$5C00-\$5FFF to \$0400-\$07FF. Then the bit-mapped graphic mode is enabled and the HiRes mode is enabled, displaying the picture.

## KOALAPainter

KOALAPainter is a software package that you get on disk when you purchase a KOALA PAD for the Commodore 64. With this program (by Audio Light/Koala Technologies), it's comprehensive single-page menu, and the KOALA PAD, even a six year old can quickly learn to make quite attractive graphics. This program is super user-friendly while being quite powerful.

At this time, KOALA provides no routine to dump your pictures to a printer, but will probably provide one in the future (for a price). KOALA does provide a routine to save your pictures to a disk file. This file can be used with the programs here to get a printer dump. In Listing 2, GDKOAL moves the 8K bit map area located at \$6000-\$7FFF to our common area of \$2000-\$3FFF. The 1K screen area starting at \$7F40 is moved to \$0400, and the 1K color memory starting at \$8328 is moved to \$D800. The background color is moved from \$8710 to \$D021. Then the bit mapped screen is turned on and the MULTicolor mode is enabled, displaying the KOALA-produced picture.

## SLIDESHOW

SLIDESHOW is a program that has appeared on several TPUG (Toronto Pet Users Group) disks. It uses a machine language program called HRSUPP to clear color memory and display a high resolution bit-mapped graphic picture loaded from disk into \$2000-\$3FFF. Quite a few digitized pictures are available in this format,

## C64-FORTH/79 New and Improved for the Commodore 64

C64-Forth/79™ for the Commodore 64-\$99.95

- New and improved FORTH-79 implementation with extensions.
- Extension package including lines, circles, scaling, windowing, mixed high res-character graphics and sprite graphics.
- Fully compatible floating point package including arithmetic, relational, logical and transcendental functions.
- String extensions including LEFT\$, RIGHT\$, and MID\$.
- Full feature screen editor and macro assembler.
- Compatible with VIC peripherals including disks, data set, modem, printer and cartridge.
- Expanded 167 page manual with examples and application screens.
- "SAVE TURNKEY" normally allows application program distribution without licensing or royalties.

(Commodore 64 is a trademark of Commodore)

### TO ORDER

- Disk only.
- Check, money order, bank card, COD's add \$1.65
- Add \$4.00 postage and handling in USA and Canada
- Mass. orders add 5% sales tax
- Foreign orders add 20% shipping and handling
- Dealer inquiries welcome

## PERFORMANCE MICRO PRODUCTS



770 Dedham Street  
Canton, MA 02021  
(617) 828-1209



including a photo of Ronald Reagan. SLIDESHOW uses the HiRes mode using only two colors; some pictures are shown in light on dark, others as dark on a light background.

SLIDESHOW pictures can be viewed and printed with the programs provided here. GDSLID in Listing 2 first clears the screen memory (1K block at \$0400) by creating black dots on a white background. Then the bit-mapped mode is enabled as is the HiRes mode, allowing the pictures to be displayed.

### PRINTER SET-UP

Before running Listing 1, first make sure the printer setup matches your printer and interface. Four constants are incorporated in the program (lines 2120-2250). PT is the printer type: 0 for C. Itoh 8510, Prowriter, and NEC 8023, and 1 for Epson MX80 with GRAFTRAX or FX80 or compatible printers like Gemini/Star. NP is the repeat counter and is automatically set up from PT. NT is the interface type: 0 for Tymac Connection and 1 for others.

SD is the secondary address required by your interface for transparent operation (use 6 for Connection, 5 for Cardco). After these changes are made, save the program to disk.

To save you the effort of typing in these programs, they are being made available as a MicroDisk. The MicroDisk, number MD-4, contains all programs in this series. In the last installment, we will get into what you have been waiting for — a method to print your pictures in full color on your existing printer.

### Listing 1

```

;SUPPORT PROGRAM FOR GDUMP
; M.J.KERYAN 3-25-84
;
5530          ORG $5530
;
5530 4C 3F 55  GOSIMN  JMP GDSIMN
;FOR SIMON'S BASIC SCREEN DUMP
; A TRADEMARK OF COMMODORE ELECTRONICS
5533 4C 8F 55  GOULTR  JMP GDULTR
;FOR ULTRABASIC-64 SCREEN DUMP
; A TRADEMARK OF ABACUS SOFTWARE
5536 4C D1 55  GODOOD  JMP GDDOOD
;FOR **DOODLE** SCREEN DUMP
; A TRADEMARK OF OMNI UNLIMITED
5539 4C F6 55  GOKOAL  JMP GDKOAL
;FOR KOALAPainter SCREEN DUMP
; A TRADEMARK OF AUDIO LIGHT
553C 4C 38 56  GOSLID  JMP GDSLID
;FOR SCREEN DUMP OF PICTURES IN
; SLIDESHOW FORMAT (TPUG)
;
553F 20 4E 55  GDSIMN  JSR ROMOUT ;SWITCH OUT ROMS
5542 20 5A 55          JSR GD1 ;MOVE MEMORY
5545 20 54 55          JSR ROMIN ;ROMS BACK IN
5548 A9 C0          LDA #$C0
554A 8D 09 50          STA $5009
554D 60          RTS
;
554E 78          ROMOUT  SEI ;IGNORE INTER.
554F A9 34          LDA #$34 ;ROMS OUT
5551 85 01          STA $01
5553 60          RTS
;
5554 A9 37          ROMIN  LDA #$37 ;ROMS BACK IN
5556 85 01          STA $01
5558 58          CLI ;RESTORE INTER.
5559 60          RTS
;
555A A9 E0          GD1    LDA #$E0 ;SET UP
555C 8D 70 55          GD2    STA FROM+2
555F A9 20          GD3    LDA #$20
5561 8D 73 55          STA TO+2
5564 A0 20          LDY #$20 ;32 BLOCKS
5566 A2 00          GD4    LDX #$00
5568 8E 6F 55          STX FROM+1
556B 8E 72 55          STX TO+1
556E BD 00 E0          FROM  LDA $E000,X ;MOVE DATA
5571 9D 00 20          TO    STA $2000,X
5574 E8          INX
5575 D0 F7          BNE FROM
5577 EE 70 55          INC FROM+2
557A EE 73 55          INC TO+2
557D 88          DEY
557E D0 EE          BNE FROM
5580 60          RTS
5581 A9 84          GD5    LDA #$84 ;SET UP
5583 8D 70 55          GD6    STA FROM+2
5586 A9 04          GD7    LDA #$04
5588 8D 73 55          STA TO+2
558B A0 04          GD8    LDY #$04 ;4 BLOCKS
558D D0 D7          BNE GD4 ;BRANCH ALWAYS
;
558F 20 4E 55          GDULTR JSR ROMOUT ;ROMS OUT
5592 A9 A0          LDA #$A0
5594 20 5C 55          JSR GD2
5597 20 54 55          JSR ROMIN ;ROMS BACK IN
559A 20 81 55          JSR GD5
559D A9 88          LDA #$88
559F 8D 70 55          STA FROM+2
55A2 A9 D8          LDA #$D8
55A4 8D 73 55          STA TO+2
55A7 20 8B 55          JSR GD8
55AA AD E0 83          LDA $83E0 ;BORDER COLOR
55AD 8D 20 D0          STA $D020
55B0 AD E1 83          LDA $83E1 ;BACKGROUND
55B3 8D 21 D0          STA $D021
55B6 20 C0 55          JSR BITON ;BIT-MAP ON
55B9 AD D6 83          LDA $83D6
55BC 8D 16 D0          STA $D016 ;HIRES OR M-C
55BF 60          RTS
;
55C0 AD 11 D0          BITON  LDA $D011
55C3 09 30          ORA #$30
55C5 8D 11 D0          STA $D011 ;BIT MAP ON
55C8 AD 18 D0          LDA $D018
55CB 09 08          ORA #$08 ;LOCATED AT
55CD 8D 18 D0          STA $D018 ; $2000
55D0 60          RTS
;
55D1 A9 60          GDDOOD LDA #$60
55D3 20 5C 55          JSR GD2 ;MOVE BIT-MAP
55D6 A9 5C          LDA #$5C
55D8 20 83 55          JSR GD6 ;MOVE SCREEN
55DB 20 C0 55          JSR BITON ;BIT MAP ON
55DE 20 E2 55          JSR MCOFF ;MULTI COLOR OFF
55E1 60          RTS
;
55E2 AD 16 D0          MCOFF LDA $D016 ;TURN OFF
55E5 29 CF          AND #$CF ;MULTI-COLOR
55E7 8D 16 D0          STA $D016 ;MODE
55EA 60          RTS
;

```

```

55EB AD 16 D0 MCON LDA $D016 ;TURN ON
55EE 29 DF AND #$DF ;MULTI-COLOR
55F0 09 10 ORA #$10 ;MODE
55F2 8D 16 D0 STA $D016
55F5 60 RTS

;
55F6 A9 60 GDKOAL LDA #$60 ;MOVE BIT-MAP
55F8 20 5C 55 JSR GD2
55FB A2 00 LDX #$00
55FD 8E 72 55 STX TO+1
5600 A0 04 LDY #$04
5602 8C 73 55 STY TO+2
5605 A9 40 LDA #$40
5607 8D 6F 55 STA FROM+1
560A A9 7F LDA #$7F
560C 8D 70 55 STA FROM+2
560F 20 6E 55 JSR FROM ;MOVE SCREEN
5612 A2 00 LDX #$00
5614 8E 72 55 STX TO+1
5617 A0 04 LDY #$04
5619 A9 D8 LDA #$D8
561B 8D 73 55 STA TO+2
561E A9 28 LDA #$28
5620 8D 6F 55 STA FROM+1
5623 A9 83 LDA #$83
5625 8D 70 55 STA FROM+2
5628 20 6E 55 JSR FROM ;MOVE COLOR MEM
562B AD 10 87 LDA $8710
562E 8D 21 D0 STA $D021 ;BACKGROUND
5631 20 C0 55 JSR BITON ;BIT-MAP ON
5634 20 EB 55 JSR MCON ;MULTI-COLOR ON
5637 60 RTS

;
5638 A0 04 GDSLID LDY #$04
563A 8C 46 56 STY GSL+2
563D A2 00 LDX #$00
563F 8E 45 56 STX GSL+1
5642 A9 10 LDA #$10 ;SCREEN COLORS
5644 9D 00 04 GSL STA $0400,X ;SET TO BLACK
5647 E8 INX ;AND WHITE
5648 D0 FA BNE GSL
564A EE 46 56 INC GSL+2
564D 88 DEY
564E D0 F4 BNE GSL
5650 20 C0 55 JSR BITON ;BIT-MAP ON
5653 20 E2 55 JSR MCOFF ;MULTI COLOR OFF
5656 60 RTS
5657 END

```

### Listing 2

```

1000 REM BASIC PROGRAM TO SUPPORT GDUMP
1010 REM M.J.KERYAN 3-30-84
1020 :
1030 IF A=0 THEN A=1: LOAD "GDUMP+MOVE",8,1
1040 IF A=1 THEN A=2: GOTO 2000
1050 POKE 20491,PT: POKE 20492,SD
1060 POKE 20493,NT: POKE 20487,NP
1070 SYS GT

```

```

1080 IF TY=2 OR TY=4 THEN MD=PEEK(53270):
MD=3-((MD AND 16)/16): POKE 20494,MD
1090 IF TY=3 OR TY=5 THEN POKE 20494,3
1100 IF TY=6 THEN POKE 20494,0
1110 GETK$:IF K$<>" "THEN 1110
1120 GETK$:IF K$="" THEN 1120
1130 IF K$="P" THEN SYS 20480
1140 POKE 53265,(PEEK(53265)AND223)
1150 POKE 53270,(PEEK(53270)AND207)
1160 POKE 53272,21
1170 POKE 53280,6: POKE 53281,15: POKE 646,0
1180 PRINT"{CLEAR}": END
2000 POKE 53280,6: POKE 53281,15: POKE 646,0
2010 PRINT"{CLEAR,DOWN2}WHICH TYPE OF PICTURE?"
2020 PRINT
2030 PRINT" 1 SIMON'S BASIC"
2040 PRINT" 2 ULTRABASIC-64"
2050 PRINT" 3 DOODLE"
2060 PRINT" 4 KOALAPAINTER"
2070 PRINT" 5 SLIDESHOW"
2080 PRINT" 6 SLIDESHOW - INVERTED"
2090 INPUT" ";TY
2100 IF TY< 1 OR TY> 6 THEN 2000
2110 :
2120 PT = 0: REM PRINTER TYPE
2130 : REM NEC/PROWRITER = 0
2140 : REM EPSON OR SIMILAR = 1
2150 :
2160 NP = 3: IF PT=1 THEN NP = 2
2170 : REM REPEAT CODE
2180 :
2190 NT = 0: REM INTERFACE TYPE
2200 : REM CONNECTION = 0
2210 : REM OTHERS = 1
2220 :
2230 SD = 6: REM SECONDARY ADDRESS
2240 : REM FOR TRANSPARENT
2250 :
2260 GT = 21808 + (TY-1)*3
2270 IF GT> 21820 THEN GT=21820
2280 IF TY=1 THEN 3000
2290 PRINT"{DOWN2}
NOW PUT IN DISK WITH THE PICTURE FILE."
2300 INPUT"{DOWN}NAME OF PICTURE";NM$
2310 PRINT"{DOWN}AFTER PICTURE LOADS, PRESS:"
2320 PRINT" P TO PRINT IT"
2330 PRINT" E TO EXIT"
2340 IF TY=4 THEN LOAD "?"+NM$+"*",8,1
2350 IF TY<> 4 THEN LOAD NM$+"*",8,1
2900 :
3000 REM CREATE A SIMON'S BASIC PROGRAM
3010 Q$=CHR$(34)
3020 PRINT"{CLEAR}1 IF A=1 THEN A=2:
LOAD"Q$" GDUMP+MOVE"Q$",8,1"
3030 PRINT"2 IF A=0 THEN A=1: GOTO 7
3040 PRINT"3 POKE 20491,"PT" :POKE 20492,"SD
3050 PRINT"4 POKE 20493,"NT" :POKE 20487,"NP" :
SYS 21808"
3060 PRINT"5 A=PEEK(53270): A=(A AND 16)/16"
3070 PRINT"6 A=3-A: POKE 20494,A: SYS 20480: END"
3080 PRINT"7 REM APPEND YOUR PROGRAM HERE"
3090 PRINT"SAVE"Q$"SIMON.GDUMP"Q$",8"
3100 POKE 631,19: FOR A=632 TO 639: POKE A,13: NEXT A
3110 POKE 198,9: NEW

```

\* NOTE: Program **GDUMP** from last month (MICRO 73:22) should be combined with above program **GMOVE** into a new program **GDUMP + GMOVE**.

# Alter Track & Sector

## on

# Vic-20 & C-64

by Edwin L. King

=====  
 Rewrite any sector on a disk without any  
 loss of data.  
 =====

**Requirements: VIC-20, C64 or any model PET with disk drive.**

The ability to examine and modify information on the disk is rather like the plumber's flaring tool. One does not need it often, but there is no such thing as a substitute. As a high school student, I was allotted one disk. After about six months of work, including developing a very fine adventure game that was 39 blocks long, the disk header got 'confused'. These was no way to use the disk without the header. The demo program DISPLAY T&S showed that at least some of the data was still good. Two things happened: first, I NEWed the disk, lost the data, and was never able to successfully recreate it; second, I developed this utility.

The program is an odd sort of hybrid. It was written and debugged on a PET 4032, revised on a VIC-20 so that it definitely works on the 4040/2031/1540 disk systems and should work on the 8050 as well, and finally was tested on the C64. It is straightforward and requires little, if any, external explanation. The BLOCK-READ/WRITE commands are used quite frequently. After all of the preliminary data is INPUTed from the user, the requested sector is displayed in a hex memory dump of the format:

### Listing 1

```

1 REM #####
2 REM ## ALTER T&S FOR 4040 DISK AND ##
3 REM ## PET 4032          BY THE FUZZ ##
4 REM #####
5 REM
6 REM      +++SET CONSTANTS+++
7 REM
10 T=0:REM  CURRENT TRACK
11 S=0:REM  CURRENT SECTOR
12 D=0:REM  DRIVE
15 HX$="0123456789ABCDEF":REM HEXCON
16 REM +++ALL OTHERS ARE TEMPORARY+++
17 DIM P$(42),R$(255)
18 OPEN 15,8,15:OPEN 2,8,2,"#0":GOSUB 10000
20 REM
21 REM      +++INPUT FROM USER+++
22 REM
25 PRINT"{CLEAR,RVS} ALTER T&S BY FUZZ "
26 PRINT:PRINT:PRINT
27 INPUT"DRIVE";D
28 INPUT"{DOWN3}TRACK,SECTOR";T,S

29 IF T=0 OR T> 35 THEN PRINT#15,"I0":CLOSE 15:
   CLOSE 2:PRINT"{CLEAR,RVSOFF,RVS}END":END
30 GOSUB 500: REM READ T&S INTO R$(I)
40 GOSUB 600: REM FOR P$'S
45 PRINT"{CLEAR}TRACK:"T"   SECTOR:"S:
   PRINT:PRINT:PRINT
46 PRINT"OUTPUT TO {RVS}S{RVSOFF}
   CREEN   OR {RVS}P{RVSOFF}RINTER"
47 GET QW$:IF QW$<>"S" AND QW$<>"P" THEN 47
48 IF QW$="P" THEN OPEN 3,4:DQ=4:GOTO 50
49 OPEN 3,3:DQ=3
50 FOR I=1 TO K-1:PRINT#3,P$(I)
51 IF I<>INT(K/2) OR DQ=4 THEN 55
52 PRINT"{DOWN2}PRESS ANY KEY TO CONTINUE"
53 GET QW$:IF QW$="" THEN 53
55 NEXT I

```

```
00: 01 23 3F 4B CC 02 0A AB
08: 20 30 40 50 60 70 80 90
```

```
F8: 01 02 03 04 05 06 70 80
```

The index-looking things are just that: "line numbers" your way of indicating which line(s) you wish to change in that sector. Naturally, the program can change any block on the disk, fix spelling in files or the directory, all under your watchful eye and direct control.

### Disk Headers

Creation of a new disk header requires knowledge of how data is stored on the disk. I would suggest a quick review of the section on advanced disk programming in your manual before making any modifications to the disk. The first thing that must be done is to make sure the disk has some of its house keeping in order. To do this, follow the program prompts to modify these lines to read as follows:

```
00: 12 01 41 00 $$ $$ $$ $$
```

```
A0: $$ $$ $$ $$ A0 32 41 $$
```

Do **not** type in the dollar signs! They are there to remind you that there will be data in those locations that should not be disturbed.

Next you must give the disk an **ID** number. Select a two digit number. Convert it into its hex ASCII value by placing the digit '3' in front of each of the digits. Enter these two values in the third and fourth positions on line A0: at locations A2 and A3. For example, if the ID number choosen was 19, then the two hex ASCII digits would be '31' and '39', and the line would look like:

```
A0: $$ $$ 31 39 A0 32 41 $$
```

```
1 9
```

The disk must have a name. This is accomplished by converting each of the letters in the selected disk name into their hex ASCII values and entering them into locations 90 through A1. If the name is less than eighteen [18] characters long, then pad the remaining locations with the shifted space character, hex A0. For example, if the disk were to be named **GAMES**, then the lines modified so far would look like:

```
56 IF DQ=4 THEN PRINT#3:CLOSE 3
60 PRINT "ARE THERE ANY MODIFICATIONS":INPUT M$
61 IF LEFT$(M$,1)="N" THEN 90
70 PRINT:PRINT "WHICH LINE";:INPUT L$
72 FOR I=1 TO K:IF LEFT$(P$(I),2)=L$ THEN Q=I:I=1000
73 NEXT
74 IF I<K+1 THEN 60
80 PRINT "{RIGHT} RIGHT$(P$(Q),LEN(P$(Q))-3);:
  PRINT "{LEFT26}";
81 INPUT Q$:P$(Q)=LEFT$(P$(Q),3)+" "+Q$
82 GOTO 60
90 GOSUB 200:REM      BREAK P$'S
95 GOSUB 100:REM      UPDATE T&S
97 PRINT "{CLEAR}":GOTO 28
100 REM ++++++++WRITE TO DISK+++++++
110 PRINT#15,"B-P";2;1
130 PRINT "{CLEAR}":FOR I=1 TO 255:PRINT#2,R$(I);:
  PRINT "{HOME}BYTE "I" OF 255":NEXT
140 PRINT#15,"U2:";2;D;T;S:RETURN
200 REM ++++++UPDATE R$(I)+++++
210 FOR I=1 TO K-1:P$(I)=RIGHT$(P$(I),LEN(P$(I))-4):
  NEXT:M=0
211 PRINT "{CLEAR}PLEASE HOLD WHILE I UPDATE THE DISK"
220 FOR I=1 TO K-1
230 PRINT "{CLEAR}":FOR J=1 TO LEN(P$(I))STEP3
240 X$=MID$(P$(I),J,2):GOSUB710
250 R$(M)=CHR$(X):M=M+1:PRINT "{HOME}BYTE "M"="X$
260 NEXTJ:NEXTI
270 RETURN
500 REM ++++++READ FROM DISK+++++
510 PRINT#15,"U1:";2;D;T;S
515 GOSUB100000
520 PRINT#15,"B-P";2;1
521 PRINT#15,"M-R"CHR$(0)CHR$(17)
522 GET#15,R$(0)
530 FOR I=1 TO 255:GET#2,R$(I):NEXT
540 PRINT#15,"B-P";2;1
550 RETURN
600 REM ++++++FORM PRINT STRINGS+++++
605 PRINT " PLEASE HOLD WHILE I  ARRANGE THE DATA"
610 K=1:FOR I=0 TO 255
615 IF R$(I)="" THEN P=0:GOTO 630
620 P=ASC(R$(I))
630 X=P:GOSUB 800
640 P$(K)=P$(K)+X$+" "
650 IF (I+1)/8=INT((I+1)/8) THEN K=K+1
660 NEXT
670 FOR I=0 TO K-1
680 X=I*8:GOSUB 800
690 P$(I+1)=X$+": "+P$(I+1)
700 NEXT:RETURN
710 REM ++++++HEX TO DEC+++++++
720 L$=LEFT$(X$,1):H$=RIGHT$(X$,1)
730 X=0:FOR B=0 TO 15
740 IF L$<>" " THEN IF MID$(HX$,B+1,1)=L$
  THEN X=X+16*B:L$=""
750 IF H$<>" " THEN IF MID$(HX$,B+1,1)=H$
  THEN X=X+B:H$=""
760 NEXT B
770 RETURN
800 REM ++++++DEC TO HEX+++++
810 H=INT(X/16):L=INT(X-H*16)
820 H=H+1:L=L+1
830 X$=MID$(HX$,H,1)+MID$(HX$,L,1)
840 RETURN
10000 REM +++++ GET ERROR STATUS +++++
10010 INPUT#15,EN,EM$,ET,ES
10020 IF EN THEN PRINT#15,"I0":CLOSE15:
  CLOSE2:PRINT "{CLEAR,RIGHT9,DOWN10}"EM$:STOP
10030 RETURN
```

00: 12 01 41 00 \$\$ \$ \$ \$ \$

90: 47 41 4D 45 52 A0 A0 A0

G A M E S

98: A0 A0 A0 A0 A0 A0 A0 A0

A0: A0 A0 31 39 A0 32 41 \$ \$

Now comes the fun part — outsmarting the computer! The only thing left to do is to rewrite the **BAM** (Block Availability Map), a special type of map in the header in which one bit equals one sector and a one in that bit indicates that the sector should not be overwritten. If there is enough data on the disk being fixed to make using this

program better than **NEWing** the disk, this would seem like an impossible, or at least forbiddingly tedious, task. But, as usual, there is an easier way. First, exit the program by answering **NO** to the question about modifications and **0,0** when asked for the track and sector. This will cause the program to update track 18, sector 0, which is the disk header that we have been working on. Once this is done, execute in immediate mode a **COLLECT** command (on the 1540 that is a **VALIDATE**.) This forces the disk drive to update its own BAM, freeing you from the task. If the header was the only thing damaged, this may be enough to correct the problem.

Otherwise, it may be necessary to play with a few of the directory tracks or program/data sectors. I leave that to the ambitious, experienced or desperate! I would suggest that, as soon as this is done or when the disk is working again, that you back it up **IMMEDIATELY** (as in right now and without hesitation).

### Program Description

The most tragically ironic thing that can happen to a CBM floppy disk is the loss of the header, particularly when the information and directory remain intact. The program is quite straightforward. Lines 10 to 15 list the permanent, or relatively permanent, variables such as current track, sector and drive. Line 17 DIMensions the two arrays: **R\$(I)** holds the single byte characters exactly as they are received from the disk and **P\$(I)** holds the line index and 8 bytes for printing, inputting and other tasks.

Lines 25 through 97 handle all input from the user. Once the requested track and sector are determined, subroutine 500 loads the 256 bytes from the requested disk block into the buffer and then into the **R\$(I)** array. Subroutine 600 converts characters into their ASCII hex form, adds the line index to generate the output strings in array **P\$(I)**. This array is dumped to the printer or display in lines 45 to 56. Lines 60 through 82 handle changes to the block. Subroutine 200 converts the updated **P\$(I)** array back to the **R\$(I)** array. The routine at line 100 rewrites the modified disk sector. Since these last two routines are a little time consuming, a few print statements are included to break the boredom. The complete run requires about 3 to 5 minutes per sector. Exit from the program occurs when an illegal track is requested: less than 1; greater than 35. **WARNING:** Under no circumstances should you tamper with line 120. The result could be a one-way trip to Disk-Never-Never-Land.

Edwin is currently attending Florida State University, majoring in Computer Science. He was introduced to computers at the Governor's Honors Program in Georgia in 1981 and followed up this start with a Computer Math class in high school where he learned BASIC and misc. PET stuff.

## PEEK A BYTE™ 64

AN ESSENTIAL DISK & MEMORY UTILITY  
FOR THE COMMODORE 64™ & DRIVE

EASY TO USE - HELP - KEYSTROKE COMMANDS

- Disk Track/Sector Editor
  - Examine and modify disk sector data
  - File Follower - memory for 150 sectors
  - Fast 1541 disk compare and error check
- Display Memory and Disk Data in Hex, ASCII or Screen Code
- Edit full page in hex or ASCII
- Disassemble memory and disk data
- Search memory for string
- Read disk drive memory
- Free sector map (BAM)
- Execute ML routines
- Printer screen dump (serial bus)
- Fast machine code! Compatible with many Basic and monitor programs

ON DISK - CAN BE BACKED UP!!

QUANTUM SOFTWARE  
P.O. BOX 12716, Dept. 64  
LAKE PARK, FL 33403

NOW ONLY  
\$29.95  
US Post Paid

TO ORDER: Send check or money order, US dollars  
Florida residents add 5% sales tax  
COD add \$2. Call 305-840-0249

Commodore 64 is a registered trademark of Commodore Electronics Ltd.



# Complete Apple Modem \$129

Single-Slot 300 Baud Direct-Connect Modem for Apple II, II+, IIe and Franklin computers

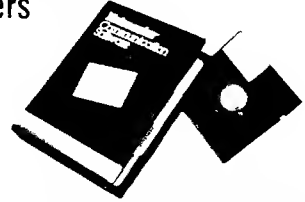

## FEATURES OF THE NETWORKER™

- ① **DIRECT CONNECT** - No acoustic coupling needed. Two modular telephone jacks - one for phone - one for line.
- ② **SINGLE CHIP MODEM** for greater reliability.
- ③ **ON BOARD FIRMWARE** contains a terminal program.
- ④ **ON BOARD SERIAL INTERFACE** - no extra cards to buy. Software selectable data format - 7 or 8 data bits - one or two stop bits - odd or even parity - full or half duplex.
- ⑤ **300 BAUD** software selectable for 110 baud.
- ⑥ **SWITCH CONTROL** for answer or quiet sits next to keyboard.
- ⑦ **CARRIER DETECT LED** gives you line status at a glance.

### ALL THIS PLUS

- COMPLETE with NETWORKER SOFTWARE to give you:
  - Text trapping of entire display into RAM memory.
  - Disk storage capability for all trapped text.
  - On screen menu and status indicators.
- FREE SUBSCRIPTION TO THE SOURCE, the popular dial up information system.
- SOFTWARE COMPATIBILITY - with all common Apple communication software.
- COMPATIBLE with both rotary and tone phones.
- FCC APPROVED - Made in USA.
- ONE YEAR MANUFACTURER'S WARRANTY.

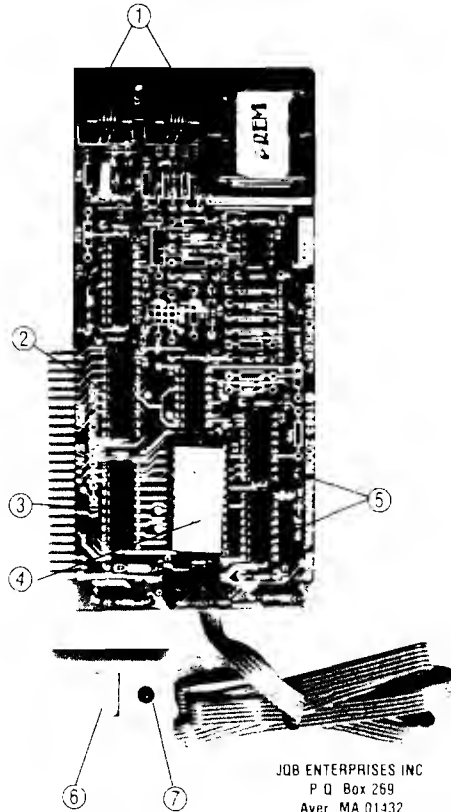

JQB ENTERPRISES INC  
P.O. Box 269  
Ayer, MA 01432

## NETWORKER™ INCLUDES A COMPLETE PACKAGE

- Networker Modem with all connecting cables.
- Modular phone line cord.
- Networker software on a disk ready to run.
- Complete instruction manual.

## NETMASTER™ COMMUNICATIONS SOFTWARE

For \$179 we include with the NETWORKER the NETMASTER Communications Software for advanced users. NETMASTER will let you transfer games, computer graphics, programs, sales reports, documents - in fact any Apple file of any size - to another computer, directly from disk to disk without errors, even through noisy phone lines.

For transferring information between computers, NETMASTER's superb error checking and high speed are an unbeatable combination. With a NETMASTER on each end, you can transfer information three to five times faster than other communications packages like Visitem™ or ASCII Express. Error free.

Your best buy in modem history. The Networker, a plug-in single-slot direct connect modem for the Apple II family of computers. Send electronic mail to a friend or business associate, use your school's computer, access hundreds of computer bulletin boards or thousands of data bases for up-to-the-minute news, sports, weather, airline, and stock information.

There's absolutely nothing else to buy. You get the modem board, communication software, and a valuable subscription to America's premier information service, THE SOURCE. For \$129 it's an unbeatable value.

This is the modem that does it all, and does it for less. The Apple Communications Card is on board, so no other interface is needed. It's 300 baud, the most commonly used modem speed. And it comes complete with NETWORKER Communications Software on an Apple-compatible disk, giving you features no modem offers.

Like the ability to lock on-screen messages into your Apple's RAM, and then move the information onto a disk for easy reference and review. A terminal program that turns your computer into a communications command center, with on-screen help menus, continuous updates of memory usage, carrier presence, and communication status.

But NETMASTER's not stuffy. It will talk to those other communications packages, but they don't work as fast and they don't check errors like NETMASTER. And NETMASTER doesn't only work with the NETWORKER modem. Even if you already have another modem for your Apple, NETMASTER is an outstanding value in communications software, so we sell NETMASTER by itself for \$79. NETMASTER requires 48k of RAM, one disk drive, and the NETWORKER or another modem.

## WE EVEN GIVE YOU SOMEONE TO TALK TO!

Your purchase of the NETWORKER with or without NETMASTER comes complete with a membership to THE SOURCE, with its normal registration fee fully waived. THE SOURCE will put a world of electronic information and communication services at your fingertips - instantly. Electronic mail and computer conferencing. Current news and sports. Valuable business and financial information. Travel services. A wealth of information about personal computing. Even games. All fully compatible with your equipment, and ready to use at once.

## To Order Call Toll Free

800-824-7888 Continental US  
800-824-7919 Alaska and Hawaii

or anywhere in the world

916-929-9091

Ask for operator #592

## MAIL ORDERS

PLEASE WRITE NUMBER OF ITEMS IN BOX

- NETWORKER \$129       NETMASTER \$79
- NETWORKER NETMASTER COMBO \$179



C.O.D.

C.O.D. ORDERS ADD \$3.00

NAME \_\_\_\_\_

ADDRESS \_\_\_\_\_

CITY \_\_\_\_\_ STATE \_\_\_\_\_ ZIP \_\_\_\_\_

Mass. residents add 5% sales tax

Total Enclosed \_\_\_\_\_

MASTERCARD     VISA     CHECK     C.O.D.

CARD NUMBER \_\_\_\_\_ EXPIRES \_\_\_\_\_

SIGNATURE \_\_\_\_\_

(Credit Card orders must be signed)



Send Orders and Make Checks Payable to

# JQB Enterprises Incorporated

P.O. BOX 269 AYER MASSACHUSETTS 01432

All Prices Quoted are for Prepaid Orders - Prices Subject to Change Without Notice



converts HLL programs to native machine codes in one continuous operation, before any attempt is made to run the HLL program.)

P-Code is a compact intermediate code that is interpreted by a P-Code interpreter program. HLL programs written with interpreters run much slower than the same programs written with a compiler because this conversion has to be done while the HLL program is running. Compilers do it only once; thereafter, only the native machine code is run. Here, the interpreter is converting a partially compiled, intermediate P-Code instead of HLL source code. This scheme results in program code that is compact and that executes faster than a pure interpreter, but not as fast as a pure compiler.

When implementing the p-System, a P-Code interpreter program is written for each different type of microprocessor, it being quicker and cheaper to write a P-Code interpreter than it is to write a complete microprocessor specific compiler. This allowed the p-System to be quickly transported to new microprocessors as they appear. That was important ten years ago. However, we can expect that fewer entirely new, general purpose microprocessors will be introduced in the foreseeable future.

General purpose microprocessors are becoming so complex and require so many years of hardware and software development that it is highly unlikely any entirely new designs will make up for the software head start that the 68000 and its 32 bit derivative, the 68020, presently enjoy.

The use of this P-Code interpreter would later be rationalized by purveyors of the p-System who emphasized the alleged portability of programs in P-Code form. (Portability refers to the ease of moving a program written on one type of computer over to another and making it run.) The truth is, there is nothing more portable than source code in a reasonably standardized (HLL). ("Source" is what you type into the computer when you sit down and write a program, "Line 10 FOR X = 1 TO 99: NEXT X" etc.)

Source code written for a micro in a given HLL can usually be transported over to a new compiler or interpreter in ASCII form. An editor can then be used

to search and replace any differences in syntax or I/O features. There is no speed penalty paid for this kind of portability — but software authors worry about the ease with which source codes can be plagiarized. Authors would rather sell programs in P-Code form which is much harder to decipher and plagiarize.

When the UCSD p-System was written, 32K of RAM was typical for a minicomputer. To avoid problems with such limited memory, program modules were designed to be loaded into the small RAM address space from a fast (expensive) hard disk as needed, a process called "module swapping" or "virtual memory." In this way a large and powerful operating system could be used in a computer with as little as 64K of RAM. Large application programs could also be written in modular fashion by committees of programmers. It is in the nature of the UCSD p-System to allow such modular programs (as well as to link HLLs, such as BASIC, to assembly language). Even individual application programmers prefer to write large business programs in small manageable modules.

On the other hand, operating system program modules called from a hard or floppy disk into a small address space are at a decided speed disadvantage; the procedure is slower than having all the operating system code in RAM at the same time. Therefore, the way to speed up this operating system is to load all those old software modules into an area of RAM called a "RAM disk" or "disk emulator." Fortunately, the 68000 has high-speed machine-language block move instructions to swap modules out of RAM instead of mechanical disk. The UCSD P-System comes alive when it operates entirely in RAM on a fast 68000 and is far superior to any other popular operating system presently available on a micro. It is a real eye opener to have an 80K text file, a powerful program editor and a compiler or assembler in RAM, all at the same time. The age old cycle of compiling your program, finding the errors, reloading the editor, reloading the text file, correcting the error, saving the corrected text file, reloading the compiler and recompiling the program is almost instantaneously achieved by pressing less than half a dozen keys.

The p-System was not always this easily used. The early acceptance of the very large (over 100K) p-System was retarded when Apple Computer tried to use it on an 8 bit 48K Apple II with only 143K on the floppy disk. To get just a directory or catalog on the video screen, the p-System filer program module had to be loaded into RAM from a floppy disk, a very slow and frustrating experience.

Ironically, the p-System worked much better on the Apple III, which had large bank switched RAM space and a hard disk. Not enough Apple IIIs were sold to improve the reputation of the p-System. We believe that the p-System on the Apple III was used by Apple Computer to write (in PASCAL) the operating system for the Lisa. Mike Markula, past president of Apple Computer, mentioned that he thought that the Apple III running Apple's version of the p-System was the best software development system on the market. It probably was at the time, but not for writing operating systems in a HLL. Writing the Lisa's operating system in a high level language was a dumb idea. This is one possible explanation for the original Lisa's slowness.

Large numbers of p-Systems were sold for the Apple II, thereby giving the P-System a reputation as being cumbersome and slow on micros in general. Its implementation in 512K RAM disk on the eight mhz or faster 68000 is helping change this image.

The p-System needs over 100K of memory because it is a very large and comprehensive operating system with a complete complement of programming tools including:

A) A program editor with search-and-replace, block move, forward and backward scrolling and save functions, which is fast and easy to use. For example, in the event of a syntax error during program compilation, the p-System will automatically and quickly, in three or four seconds, reload the source text file from RAM disk and return the cursor to the error on the screen with one or two keystrokes. This is handy for writing compiled programs by trial-and-error. (Don't laugh, it works). The p-System editor is far better than ED on CP/M 68K (which, admittedly, isn't saying

much). It is a real eye opener to have a 100K text file in RAM and be able to jump from the beginning to the end in only three seconds (no mistake — 3 seconds!!!!). Try that on your Apple II.

At one time we did a lot of 6502 assembly language programming on the Apple II, and we were not satisfied with the speed or the memory capacity. We investigated ways to get all those 6502 assembly language text files out of the Apple II into the Sage II in p-System editor text file format, and finally discovered a way to upload Apple II assembly language text files to the P-System editor. We were then able to cross assemble them after a few changes with the editor. (An unexpected bonus, most welcome.) BASIC and PASCAL text files were also uploaded. The secret to doing this is to use the Apple II serial printer interface and a utility on the p-System called "TEXTIN". The P-System program editor's replace function is easily used to change 6502 assembly language pseudo-ops and Applesoft BASIC commands to conform to p-System language requirements.

B) A general purpose 68000 macro assembler (and cross-macro assembler) which assembles code for almost any microprocessor. Each set of mnemonics is loaded separately.

C) A linker to link assembly language modules, as well as high level language modules including BASIC, to other high level language modules as well as to themselves. You can even link a PASCAL procedure to a BASIC program and use it as a subroutine.

D) A very fast, comprehensive and flexible disk operating system.

E) Compilers for BASIC, FORTRAN, PASCAL and MODULA II, among other HLLs. These compilers compile to P-Code, which can then be partially compiled to 68000 native code using the p-System's Native Code Generator. (Unfortunately at the present time, this Native Code Generator does not compile all P-Code to native code, only selected routines. The P-Code interpreter program is still needed in RAM to handle the remaining routines). A further increase in speed could be achieved by rewriting this Native Code Generator to compile all P-Code to native code. The entire p-System could then be compiled to native 68000 code.

UNIX operating systems are getting a lot of attention in the computer press lately. UNIX has several desirable features as does CP/M-68K. The p-System, however, has much more application software to run on the 68000 than CP/M-68K or any UNIX-like operating system [a reason in itself why the p-System is becoming the de facto standard operating system on the 68000]. To my knowledge, there are less than a dozen application programs for CP/M-68K or UNIX. At last count over 250 packages were available for the p-System. Most of this application software for the p-System was first written for Apple IIs with the PASCAL language card and minicomputers running the UCSD p-System. There are several of each, very good wordprocessors, data base and spreadsheet programs. As the use of low cost 68000 computers that use the UCSD p-System grows, the body of copyable software for the p-System should also increase. A 248 page book that lists all the software is available from Softech Microsystems, San Diego, CA., for six dollars.

Although the p-System was written in PASCAL, compiled to P-Code, then interpreted and module-swapped, it runs faster on a 8 MHZ 68000 micro, using a RAM disk, than any UNIX or UNIX-like operating system that we know of. Not only is UNIX a highly modular operating system, but it has the greater disadvantage of having been written on an older, more memory limited, minicomputer than that used to write the p-System. Most — if not all — UNIX-like systems were written in 'C' and compiled to assembly language, then assembled to native machine code (which is in the nature of writing with 'C').

'C' based operating systems should be faster than systems written with a pseudo compiler which uses a P-Code interpreter; therefore, UNIX should be faster than the p-System — but it isn't. One possible reason for this is the fact that UNIX program modules are stored on hard disk in fragmented blocks and swapped in from hard disk to small areas of RAM (virtual memory). Thus the additional unnecessary complexity and number of modules in UNIX make UNIX slower. Maybe it will come alive when 2

megabyte RAM disks are common. UNIX is also a multi-user operating system when what is really needed is a one CPU per user, net-worked operating system. (Single CPU, multi-user systems, went out with high priced, discrete chip central processing units such as found in mainframes and minicomputers. Microcomputers (less disk drives) now cost little more than dumb terminals used with the old multi-user CPUs.) These are some of the reasons that the UNIX running, multi-user, Fortune 500 and the Radio Shack Model 16, 68000 micros are slow, compared to a single-user 68000 running the p-System.

The UCSD p-System in RAM disk on a 68000 is usefully fast; UNIX, at this time, is not. Yet, the p-System's performance could be improved even over its present capabilities if it were rewritten to take advantage of the 68000's large (16 megabyte) linear address space. Rewriting the p-System would preclude having to swap modules from RAM disk and thereby make it more efficient.

Nevertheless, the p-System is becoming the de facto standard, 68000 personal computer, operating system, something the 68000 community needs. There are already a surprising number of low-cost 68000 microcomputers running the UCSD P-System. The following microcomputers deserve serious consideration, described in order of usefulness-per-dollar, according to our own personal preferences. While our tastes may not be the same as everyone's, it would be nice to think that at least we represent a reliable cross-section of knowledgeable micro users:

## Sage II

(\$3200) Sage Computer

Upon reading an ad in "Byte" for the Sage, we contacted Sage Computer for dealer information. We were pleasantly surprised when a knowledgeable salesman appeared and demonstrated the machine, which initially impressed us because it came with p-System, wordprocessing, spreadsheet, PASCAL and a 68000 macro assembler, along with an assortment of other software. When we saw the extensive

documentation, the schematic, the memory map, the powerful system monitor in 16K byte EPROM, and the monitor source listing — in other words, a completely open system — we were sold.

The experience was like that of a few years before, when we were first introduced to the Apple II, except that with the Sage we were given an extensive assortment of software and a built in printer interface just to start up our acquaintance. In short, we bought a Sage and have been pleased with this supermicro to this day; it has proven its reliability and speed.

Floppy disk access and load times (20K per sec.) execute on the Sage about ten times faster than on the Apple II disk operating system (DOS) and BASIC programs run four times faster than on IBM's Personal Computer. It is as fast to program in high level compiler languages as using interpreters on 8-bit machines. Our assembly language programming productivity doubled with the Sage. Word processing spelling checkers, too slow previously, are viably fast.

An unexpanded, 256K Sage II costs approximately \$2600 (discounted). You can plug in your own 64K bit dynamic RAM chips for 512K bytes and your own second Mitsubishi floppy disk drive; sockets, cables and connectors are provided with the unexpanded machine. Industry standard, one hundred and fifty nanosecond, 64K bit RAM chips cost about six dollars at the present, and 36 chips make up 256K of parity RAM memory. A Mitsubishi floppy is presently about \$350.

The Sage II boasts 24 bit address, 16 bit data bus, expansion connectors. It comes with a built-in Centronics parallel printer port, an IEEE-488 port and two RS-232 serial ports, one of which is used with the terminal, the other already set up for a modem. The standard drive uses five-inch double-density double-sided floppies with 640K on each disk. Very expensive options include hard disk up to forty megabytes and a six-user system with 1 megabyte RAM. Unfortunately the clock is not battery backed up.

Several other operating systems will run on the Sage, including CP/M-68K, Mirage, PDOS, BOS/5 and Idris (a Unix-like operating system). Languages that run under the standard

and optional operating systems are several versions of Fortrans, BASIC, ADA, Forth, Cobol, Microcobol, APL, Modula II and several 'C's. The Sage requires a separate RS232 terminal.

### Pinnacle

(\$3895). Pinnacle Systems

The Pinnacle comes with just the p-System run-time package. The rest of the p-System is optional. The Pinnacle is equipped with two double sided, quad density, 800K half height floppy drives. 512K byte parity RAM is standard. RAM expansion to one megabyte costs \$1295. Pinnacle is extremely cost effective particularly in the 10 MEG hard disk version at only \$5995.

*[Editor's Note: The authors included two paragraphs questioning Pinnacle's claim to run at 12 Mhz. We contacted Pinnacle and they stated that "... the Pinnacle runs at 12 Mhz and has done so since June of 1983. This is possible by using prequalified selected parts."]*

The Pinnacle has no less than seven serial ports, one parallel printer port, an Omninet networking bus and a Sasi hard disk interface in the basic machine, as well as a battery-backed-up clock and calendar.

The video display and keyboard aren't built-in on the Pinnacle, unlike the Apple II; a separate RS232 serial terminal is required. However, not having a built-in display and keyboard can be advantageous, because the buyer only pays for what he needs. Separate 19.2K baud serial terminals are also faster than most built-in HiRes bit-mapped displays (another reason the 68000 bit-mapped Apple Lisa is so slow?). This is due to the dedicated CPU in all terminals (multi-processing if you will) that has nothing else to do but update the screen while bit mapped displays are usually updated by the main CPU. An RGB color terminal costs about the same as an RGB board and color monitor for the Apple II or the IBM-PC, and this way the buyer can choose according to preference. Something not to overlook is that most microcomputers can be used as terminals.

The question being asked these days is, "Will the company be here next year?" Pinnacle Systems is part of a

larger company that specializes in manufacturing complete computer boards. The excellent design of the four layer Pinnacle processor board is testimony to their expertise in this area.

### Dimension 68000

(Under \$4000) Micro Craft Corporation

This machine reputedly took 16 months to engineer. Its 68000 chip runs at 7.2 Mhz and optionally runs the p-System. Idris, Mirage, Unix 5, S1 and Concurrent DOS 4.0 will be available soon. CP/M-68K is standard. The amazing attribute of the Dimension is that it will run almost any other company's or microprocessor's software. Micro Craft has engineered plug-in CPU cards that not only run the software of other popular machines, but automatically reconfigure the disk drive format and video display to imitate the hardware configuration of the simulated machine. In other words, when imitating an Apple II, the disk drives have 143K and the display has 40 characters across, upper case only.

The display can handle up to 100 characters across and up to 48 lines. There is a color graphics mode, 160 X 480 pixels in 16 colors and a black and white graphics mode of 640 X 480 pixels. 512K of RAM can reside on the main board. The Dimension comes with 256K of RAM. Chips can be plugged in to increase memory up to 512K. A six-slot internal expansion but is provided. 3.5 megabytes (!) of RAM can be plugged into these expansion connectors, using 64K bit dynamic RAM chips on 512K byte plug-in cards costing \$1295 each. When 256K bit dynamic \$37 RAM chips become lower in cost (next month), 12.5 megabytes in the box are possible, although the power supply might have to be changed to install 12.5 megabytes of RAM. An optional expansion interface will allow another 4 megabyte of directly addressable RAM for a total of 16MB.

To put 16 megabytes of RAM in perspective, the largest and most expensive supermini that the Digital Equipment Corporation manufactures is the VAX 11/782, which costs about twice as much as a VAX 11/780 and the maximum amount of memory it can address is 8 megabytes (Mini-Micro Systems magazine.)

Extra-cost half-height five inch double-sided 800K byte floppies are available. The standard machine comes with two 5-1/4 inch, 400K byte floppies; serial, parallel and game controller interfaces. A 50 megabyte hard disk and controller costs \$4995.

### **Hewlett Packard 9816A**

(\$3995) Hewlett-Packard

The HP 9816A is a 68000 personal computer with a too small, nine inch CRT having a 400 X 300 pixels graphic capability. The indispensable disk drives are a lot extra. The HP 9816A uses the 270K Sony three-and-a-half inch floppy disk drives at only \$900 each, but the hard-shell media for this drive are presently hard to find and expensive. The use of these drives and media on the Apple Macintosh will probably change this. Dual 540K, five inch drives cost \$2230. The same Tandon drives bought "off the shelf" from an electronics distributor cost \$250 each.

The HP 9816A runs the UCSD p-System version 2.1 (everybody else uses version 4.13) at an extra \$1515. There are 128K RAM, a well thought out RS232 and HP-IB (IEEE 488) interfaces built in. Additional RAM cost about \$1100.00 for 256K, while on the Sage or the Dimension 256K RAM would cost \$300 to \$650. There are various other well engineered, expensive options on the HP 9816A such as plotters and graphics tablets. Apparently, HP means High Price.

### **Corvus Concept**

(\$3995) Corvus Systems

The UCSD p-System runs on the Corvus Concept as a \$695 option. The CPU is an 8 mhz 68000. It has a large (15 inch) crt display, 132 columns by 66 lines and 720 X 560 HiRes graphics. The display is black and white only. The bit-mapped design makes the display update slower than a 19.2K baud terminal. A large speed improvement could be made by Corvus if they put a dedicated micro in the display with the sole purpose of updating the display.

Believe it or not, the Corvus Concept has a 50 pin Apple II expansion bus! There are two built-in

RS232 serial interfaces and an Omninet interface. The Corvus also has a battery-backed-up clock and calendar and 512K of RAM in the box. From a marketing viewpoint, a weakness of the Concept is that it doesn't come with any floppy disk drives. Single 750K five inch floppies are a lot extra (\$750). A further handicap is a rather slow access time (1 megabit per second) Omninet, networked hard disk. A hard disk with an eight bit parallel interface is also available that should be somewhat faster.

However, the Corvus Concept is worth considering if the system must support more than about four users, because it can utilize a network. Multi-using eventually boggs down any single CPU, even the 68000. By comparison, Digital Equipment Corporation offers the VAX 11/780 with 96 users. Can you imagine 96 users, all trying to compile different programs at the same time, on one CPU no faster than a fifty dollar, 12 mhz 68000 microprocessor? (Maybe Digital doesn't think all 96 users are going to be on-line at the same time.) Multi-user, single CPU time-sharing systems are simply obsolete. Networked microprocessor CPUs are the only answer.

### **Saybrook**

(\$995) Analytical Engines

This is an add-on 68000 computer for the Apple II. It has an 8 mhz or optional 12.5 mhz CPU and 128K of RAM on-board, expandable to 512K with 256K bit chips. The Apple II quickly communicates with the 68000 computer by means of DMA (direct memory access). The weakness of this approach is the Apple's slow disk operating system and the limited storage capacity 143K Apple disk drives. On the other hand, program execution and video screen updates are very fast, particularly for HiRes animated graphics. (The Apple II has a rather unique and very fast screen update scheme. In effect it is a dual processor. The first is the main 6502 CPU. The second, very simple processor, made from discrete TTL chips, has nothing else to do but refresh the screen and the dynamic memory.) Analytic Engines claims 10 to 30 times the speed of the Apple II with the 68000

running programs out of RAM dedicated to the 68000.

The computer comes with the p-System and a choice of one of the following languages: UCSD PASCAL, FORTRAN, BASIC compilers or an Applesoft-compatible BASIC interpreter. The Saybrook has a 24-hour clock (but it's not certain that this clock is backed up by a battery).

These are the presently available low-cost 68000 microcomputers running the UCSD p-Systems. In the near future other 68000 computer manufacturers will probably hitch a ride on the p-System bandwagon, the mouse and Apple's Macintosh to the contrary. The Apple Lisa II would be a fine candidate as would the Radio Shack Model 16 and the Fortune.

You have to try the p-System on a fast 68000 machine with RAM disk to understand the difference between the various other operating systems and the very real advantages offered by the p-System and a fast and powerful 68000. Any of the above microcomputers (where available) are worth a trip to the computer store.

### **Manufacturer's References**

Analytical Engines  
3415 Greystone, #305  
Austin, TX 78731  
512/346-8430

Corvus Systems  
2100 Corvus Drive  
San Jose, CA 95124  
408/559-7000

Hewlett-Packard  
19447 Pruneridge Avenue  
Cupertino, CA 95014

Micro Craft Corporation  
4747 Irving Blvd, Suite 241  
Dallas, TX 75247  
214/630-2562

Pinnacle Systems  
10410 Markison Road  
Dallas, TX 75238  
214/340-4941

Sage Computer  
4905 Energy Way  
Reno, NV 89502  
702/322-6868

# Atari/Epson Custom Characters

Transfer almost unlimited customized alphabets  
to paper - accurately.

by Mike Bassman

**Requirements:** Atari 400/600/800/1200, 850 Interface, Epson MX-80 with Graftrax +, or MX-80 FT or MX-100, or FX-80

When it comes to dealing with text, the Atari computers have a marvelous flexibility. Naturally, they can display the usual upper and lower case, numbers and punctuation. Besides that, they also have inverses of all the standard characters, plus lines, card suits and a host of other graphics characters. If you're not satisfied with this selection, you can make your own custom characters which has led to programs using gothic, script and other interesting fonts. You can generate your own fonts with one of the many character-editing programs that have been published. All these can easily be displayed on the screen, but transferring them to paper is not normally possible.

Why? There are a number of reasons. The main one is that printers are not designed for any one particular computer. Only alphanumerics and punctuation symbols are in the standard ASCII table. The maximum possible number of characters is 256 (each character stored uses one byte; a byte can be in the range of 0-255, hence, 256 possibilities). These standard characters fill up less than half of the available room, so Atari decided to pack the rest with inverse and graphics characters. Radio Shack, instead, throws in a combinations of block characters. Commodore has inverse characters and different graphics characters. The point here is that apart from normal characters, no two computers have the same set of 'extra' characters. As such, a printer

manufacturer catering only to one computer would have a limited audience. Epson has a viable solution; they have their own characters, an italic set and a few graphics characters. The important fact is that the Epson printers have full graphics abilities. We can take advantage of this to generate Atari's own special and custom characters. All you need is the appropriate software. I've included listings of two somewhat similar programs; one useful and one frivolous.

## Any-Text File Lister

The program shown in Listing 1 lists files to an Epson printer. At first this may not sound amazingly useful. I mean, from Basic, this is merely a matter of issuing a LIST "P:" command. From the DOS utilities menu you can copy a text file to P:, but what makes this program useful is that its listing is accurate: it includes all the graphics and inverse characters. If you've ever tried listing a program with graphics or inverse, you'll know that inverse shows up as italics and graphics characters show up as meaningless garbage, or some odd control character will throw the printer into a stupor that will mess up the rest of the listing. This program lists out a program in its exact form, graphics and all. If examined closely, you can see that this program was used to list itself.

Using this program is simple. If there is a Basic program you wish to list, load it in from disk (or cassette) and then re-save it out under a different name using a LIST "D:name" command, rather than the SAVE command. The purpose behind this is to have the program as text, rather than encoded in Basic keywords. If it's a text

file you want to print, you clearly don't have to do this. Next run this program and enter the name of the file your text is in. That's all it takes.

## Custom Font Message Printer

The program in Listing 2 will print anything you want in a custom character set. If you've ever had a desire to see a message in script or computer-type letters or whatever, this will do the trick. All you need to have are the custom fonts stored on disk (or cassette) in a nine sector file as generated by Instedit [APX] or just about all of the other character generators. There are a few examples of its handiwork shown in the accompanying chart. From top to bottom, the alphabet is shown in computer-style, gothic, fancy fonts and a few others. Making use of this program (custom font message printer) is even easier than the file lister above. Just run it and, when prompted, enter the name of your character set and then the message you want printed. If your character set is stored on cassette, type C: for the character set name, when asked.

## Custom Font Variant

Listing 4 shows a program that looks a good deal like the custom font message printer. In fact, it is a cross between that program and the program lister. It does the same thing as the custom font program except that it prints out a whole file in the new font rather than a one line message. This would be useful to take a file generated with a word processing program and, after putting it through this program, end up with a professional looking document printed

in a pleasant typeface of your choice. There are some commercially available programs which do just this. Using it consists simply of entering the name of the font and the name of the file to be printed.

### Entering The Programs

Typing in these programs can be a bit of a problem because of the machine language subroutine embedded in them. The Basic part is easy to do. The straightforward approach is to type those graphics characters just as you see them. The graphics keyboard included in the Atari Basic Reference manual is a guide to finding all the right keys (the back cover has a relatively easy to use diagram). If you do decide to do it this way, make sure that you save the program before running it. Any typo could bomb the computer; let this be a word to the wise.

Another method is to assemble the source code using the Assembler/Editor cartridge or one of the many other assemblers available. The source code for the machine language portion is shown in Listing 3. The programs all use the same machine language subroutine, so the most difficult part only has to be done once, even if you want all the programs. The amount of code needed to be typed in this way is longer than typing the graphics characters, but fortunately the code is made up of normal alphanumeric characters. You then assemble the code to a disk file and modify either of the programs to load in this subroutine from that disk file. If you choose to do it this way (not highly recommended), the changes to listings 1 & 2 are as follows:

- 1 - Delete lines 11,12,13.
- 2 - Add lines 90-130 as shown.

```

90 OPEN #3,4,0,"D:ASSEM.OBJ"
100 FOR K = 1 TO 6:GET #3,X:NEXT K
110 TRAP 130:K = 0
120 K = K + 1:GET #3,X:
ML$(K,K) = CHR$(X):GOTO 120
130 CLOSE #3

```

The modification here can be used with both programs and with the variant by changing the line numbers. The filename in line 90 is your assembled version of the source code. These programs are very similar, so if you want to have all of them, I would recommend typing in one of them, saving it, and then modify it

until you have the other program. Conversely, if you're only bothering with one program, keep in mind it doesn't take much effort to obtain the other ones.

### Theory of Operation

You already have all you need to know to get these programs working. But if you want to know how they work, and maybe do clever things of your own with your Epson, read on.

You may ask how we get a large number of new character sets out of a printer normally limited to regular and Italic characters, in various sizes. Well, these programs don't exactly print out new characters, they draw them. All reasonably new Epson printers (or old ones retrofitted with Grafrax +) have the ability to do graphics. There's no reason to limit use of the graphics to charts or drawings; you can also improve on your regular text performance. The basic task to be accomplished is to get a character from the file, find out how the character is drawn, send this information over to the Epson and repeat this procedure until you reach the end of the file (or message).

### Where Character Shapes Are

The character set in use can be found at the address specified by PEEK(756)\*256. Location 756 (2F4 hex) is the Character Base register, holding the high byte of the address. The low byte is assumed to be zero. The standard character set is at \$E000. Though the topic has been more comprehensively covered in other articles, let me quickly refresh your memory on how they (the characters) are stored. Each character can be 8 bits wide and 8 bits high, total of 8 bytes (64 bits). Usually there is a little room on top, bottom and the sides so that characters won't be squeezed too tightly together when shown next to each other. Each row of a character is one byte and there are eight rows going from the top to bottom of any one character. So the capital letter "E" is represented in memory like so:

```

00000000 byte = $00
01111110 byte = $7E
01100000 byte = $60
01111100 byte = $7C
01100000 byte = $60
01100000 byte = $60
01100000 byte = $60
01111110 byte = $7E
00000000 byte = $00

```

### Getting a Character to the Printer

This is how the computer reads a normal or redefined character. Now we've got to send this information out to the printer. Things would be simple if the printer could be fed the character a byte (row) at a time, just like the computer understands them. But this isn't the case. While the computer reads a character a row at a time, from top to bottom, the printer head is a vertical column, so it does each character a column at a time, from left to right. This makes life difficult. What we're going to have to do is take each byte that forms a row of the character and take off the leftmost bit. We're going to take these bits off all eight rows, line them up in a column and then send the column off to the printer. Then we do this for the eight columns that make a character, from left to right. Visually, this means that instead of taking slices of bits off the top of say, that 'E' we saw earlier, we take slices vertically off the sides.

### Theory into Code

This cut and paste type of operation with bits can be turned into a basic program. To output one complete character, we need two loops, one going from left to right sending out columns of data and an inner loop that puts together these columns. There's a chart showing each pin of the print head and what is needed to turn it on:

```

128 - o
64 - o
32 - o
16 - o
8 - o
4 - o
2 - o
1 - o

```

For each of the pins you want to turn on, add that number. For example sending a 34 would turn on the third pin from the top and the second from the bottom. It's no surprise that each of these values is 2 to the power of the pin number (pins numbers range from 0 to 7, bottom to top), and we'll use this fact. To find out if we want to turn on a pin, we look at a row of the character, AND it with the column number we're up to and, if we get a positive value, we know to turn it on. Column numbers, not coincidentally, are represented just like the pin numbers but from right to left, instead of bottom

**Listing 2**

```

; CUSTOM CHARACTER DUMP
; MIKE BASSMAN
;
0342      ICCOM      EQU $342
0344      ICBAL      EQU $344
0345      ICBAH      EQU $345
0348      ICBL      EQU $348
0349      ICBLH      EQU $349
0680      B          EQU $680
0681      G          EQU $681
0682      SUM        EQU $682
002C      VL         EQU $2C
0685      J          EQU $685
0687      AD         EQU $687
0689      VALUE      EQU $689
068A      MASK       EQU $68A
068B      RESULT     EQU $68B
068C      INVR      EQU $68C
;
5000      ORG $5000
;
; SAVE NUMBER OF ARGUMENTS
; CHAR MEM HI
; CHAR MEM LO
; SET INVERSE VIDEO FLAG
;
5000 68      START    PLA
5001 68      PLA
5002 8D 88 06 STA AD+1
5005 68      PLA
5006 8D 87 06 STA AD
5009 68      PLA
500A 68      PLA
500B 8D 85 06 STA J
500E A9 00    LDA #$00
5010 8D 8C 06 STA INVR
5013 AD 85 06 LDA J
5016 C9 80    CMP #$80
5018 90 0A    BCC INIZ
501A 29 7F    AND #$7F
501C 8D 85 06 STA J
501F A9 FF    LDA #$FF
5021 8D 8C 06 STA INVR
;
; SETUP ROW/COLUMN COUNTERS
;
5024 A9 07    INIZ     LDA #7
5026 8D 80 06 STA B
5029 A9 00    FIRSTG  LDA #0
502B 8D 81 06 STA G
502E 8D 82 06 STA SUM
5031 A9 00    SETVL   LDA #0
5033 85 2C    STA VL
5035 85 2D    STA VL+1
5037 AD 85 06 LDA J
503A A2 03    LDX #3
;
; MULTIPLY BY 8
;
503C 18      MULT8  CLC
503D 06 2D   ASL AL+1
503F 0A      ASL A
5040 90 02   BCC LOWDO
5042 E6 2D   INC VL+1
5044 CA      LOWDO  DEX
5045 D0 F5   BNE MULT8
5047 85 2C   STA VL
5049 18      CLC
504A 6D 87 06 ADC AD
504D 85 2C   STA VL
504F 90 02   BCC ADDHI
5051 E6 2D   INC VL+1
5053 18      ADDHI  CLC
5054 A5 2D   LDA VL+1
5056 6D 88 06 ADC AD+1
5059 85 2D   STA VL+1
505B 18      CLC
505C A5 2C   LDA VL
505E 6D 81 06 ADC G
5061 85 2C   STA VL
5063 90 0A   BCC ANDIT
5065 E6 2D   INC VL+1
5067 B0 06   BCS ANDIT
5069 18      ELONG  CLC
506A 90 C5   BCC SETVL
506C 18      LONG   CLC
506D 90 BA   BCC FIRSTG
506F A0 00   ANDIT  LDY #0
5071 B1 2C   LDA (VL),Y
5073 4D 8C 06 EOR INVR
5076 8D 89 06 STA VALUE
5079 AE 80 06 LDX B
507C E0 00   CPX #0
507E D0 05   BNE SMALL
5080 A9 01   LDA #1
5082 18      CLC
5083 90 08   STA B
5085 A9 02   SMALL  LDA #2
5087 CA      DO     DO
5088 F0 03   BEQ AMAIN
508A 0A      ASL A
508B D0 FA   BNE DO
508D 8D 8A 06 AMAIN  STA MASK
5090 2D 89 06 AND VALUE
5093 8D 8B 06 STA RESULT
5096 C9 00   CMP #0
5098 F0 1F   BEQ NEXTG
509A 38      SEC
509B A9 07   LDA #7
509D ED 81 06 SBC G
50A0 C9 00   CMP #0
50A2 D0 05   BNE POWER
50A4 A9 01   LDA #1
50A6 18      CLC
50A7 90 09   BCC DOSUM
50A9 AA      POWER  TAX
50AA A9 02   LDA #2
50AC CA      DO2    DEX
50AD F0 03   BEQ DOSUM
50AF 0A      ASL A
50B0 D0 FA   BNE DO2
50B2 18      DOSUM  CLC
50B3 6D 82 06 ADC SUM
50B6 8D 82 06 STA SUM
50B9 EE 81 06 NEXTG  INC G
50BC A9 08   LDA #8
50BE CD 81 06 CMP G
50C1 D0 A6   BNE ELONG
50C3 A2 40   LDX #$40
50C5 A9 0B   LDA #B
50C7 9D 42 03 STA ICCOM,X
50CA A9 82   LDA #SUM
50CC 9D 44 03 STA ICBAL,X
50CF A9 06   LDA /SUM
50D1 9D 45 03 STA ICBAH,X
50D4 A9 01   LDA #1
50D6 9D 48 03 STA ICBL,X
50D9 A9 00   LDA #0
50DB 9D 49 03 STA ICBLH,X
50DE 20 56 E4 JSR $E456
50E1 18      NEXTB  CLC
50E2 CE 80 06 DEC B
50E5 10 85   BPL LONG
50E7 60      RTS
50E8      END

```

to top. This strategy is represented in the following piece of Basic-like code.

```

J=ASC(CHARACTER)
A=ADR(STARTOFCHARACTER-DATA)
FOR B=7 TO 0 STEP -1:REM the outer column loop.
SUM=0:REM clear the print head counter.
FOR G=0 TO 7:REM inner loop totals up a column.
Y=PEEK(A+G+J*8):REM get the row value.
X=INT(2 B+.5):REM the column number.
Z=X AND Y:REM you can't do a boolean AND in Basic, but you get the

```

idea.

```

IF Z THEN SUM=SUM + INT(2 (7-G)+.5):REM add pin value to running total if we should.
NEXT G:REM do it for the entire column.
PUT #4,SUM:REM output the column to printer.
NEXT B:REM now do this for all 8 columns.

```

This is ridiculously slow when done in Basic, so the machine language subroutine just uses this algorithm, but runs infinitely faster. There is only one other thing you need to know to control the Epson. Before you start

sending all this pin information, you have to tell it to go into high resolution mode and then say how many columns of graphics you want. Turning on graphics is done by sending an ESCAPE, then a "k". You tell it how many columns of graphics by sending out two more values, the first being the low byte of the # of columns, the second being the high byte.

That's all there is to making your Epson print anything you want. The programs listed here are only a few of the possible applications. Using some of the information shown here, you can invent new and interesting uses for your printer.





How would you like to have an entire issue of MICRO printed in a GOTHIC font? While it might be interesting at first, I am sure that the novelty would wear off very quickly.

Printer Sample

Listing 4

```

10 DIM M$(300)
11 M$(1)="hh / h / hh / 0 / 1 / 2 / 3 / 4 / 5 / 6 / 7 / 8 / 9 / A / B / C / D / E / F / G / H / I / J / K / L / M / N / O / P / Q / R / S / T / U / V / W / X / Y / Z / [ / \ / ] / ^ / _ / ` / a / b / c / d / e / f / g / h / i / j / k / l / m / n / o / p / q / r / s / t / u / v / w / x / y / z / { / | / } / ~ / "
12 M$(92)="0, 1, 2, 3, 4, 5, 6, 7, 8, 9, A, B, C, D, E, F, G, H, I, J, K, L, M, N, O, P, Q, R, S, T, U, V, W, X, Y, Z, [, \, ], ^, _, ` , a, b, c, d, e, f, g, h, i, j, k, l, m, n, o, p, q, r, s, t, u, v, w, x, y, z, {, |, }, ~, "
13 M$(198)="0 1 2 3 4 5 6 7 8 9 A B C D E F G H I J K L M N O P Q R S T U V W X Y Z [ \ ] ^ _ ` a b c d e f g h i j k l m n o p q r s t u v w x y z { | } ~ "
17 I=0: DIM X$(11), M$(255)
20 X$="h / - / V / "
30 DIM B$(1024): A=ADR(B$)
40 DIM N$(15), NM$(15), MM$(15)
50 GRAPHICS 18
60 POSITION 4,1: ? #6;"CUSTOM FONT"
70 POSITION 2,5: ? #6;"message printer"
80 POSITION 5,9: ? #6;"for epson"
100 FOR K=1 TO 2000:NEXT K
110 ? "Please enter the name of the disk file which contains the character font to be used (ex: GOTH.SET)"
120 ? :? "Name of character set:"
130 TRAP 390: NM$="D:": INPUT N$: NM$(LEN(NM$)+1)=N$
140 OPEN #3,4,0,NM$
150 FOR K=0 TO 1023
160 GET #3,B
170 POKE A+K,B
180 NEXT K: CLOSE #3: TRAP 400
200 GRAPHICS 0: POSITION 2,6
210 ? "Please enter then name of the disk file to be printed. (ex: FILE.BAS)"
220 ? :? "Name of program:"
230 TRAP 350: MM$="D:": INPUT N$: MM$(LEN(MM$)+1)=N$
240 OPEN #3,4,0,MM$
250 INPUT #3,M$
260 TRAP 400
270 Q=LEN(M$): IF LEN(M$)>60 THEN Q=60
280 OPEN #4,8,0,"P": TRAP 420
290 I=0: J=Q*8: IF J>255 THEN I=1: J=J-256
300 PUT #4,27: PUT #4,ASC("K"): PUT #4,J: PUT #4,I
310 FOR K=1 TO Q
320 J=ASC(M$(K,K)): IF J<96 AND J>31 THEN J=J-32
324 IF J<224 AND J>159 THEN J=J-32: GOTO 330
326 IF J<160 AND J>127 THEN J=J+64
330 DUMMY=USR(ADR(M$),A,J)
340 NEXT K: PUT #4,27: PUT #4,64: CLOSE #4: LPRINT
342 IF Q<LEN(M$) THEN M$=M$(61): GOTO 270
345 TRAP 350: GOTO 250
350 CLOSE #3: GRAPHICS 18
360 POSITION 6,4: ? #6;"all done"
370 FOR K=255 TO 0 STEP -1: SOUND 0,K,12,5: SOUND 1,255-K,12,3: NEXT K: SOUND 1,0,0,0
380 GRAPHICS 0: END
390 ? :? "ERROR IN LOADING CHARACTER SET": ? : CLOSE #3: GOTO 110
400 ? "ERROR: PRINTER OR INTERFACE NOT READY"
410 END
420 ? "ERROR IN OPERATION - PLEASE TRY AGAIN"
430 END

```

# Extended Precision Arithmetic in BASIC

Greater mathematical precision and a way to calculate the lunar-based Jewish Calendar.

by Rolf B. Johannesen

Many common implementations of BASIC in microcomputers today use a binary representation for real numbers which has either 24 or 32 bits for the mantissa and 7 bits for the characteristic. This translates to either 6.1 or 9.5 decimal digits of precision, respectively. Occasionally, greater precision is required: statistical calculations are notable in requiring many extra digits of precision during the intermediate stages of calculations because so many results are derived as the differences between two numbers that are almost equal, so that several of the most significant digits are lost in a single step.

Computer software for processing arithmetic statements never warns that bits have overflowed the mantissa, even though this will inevitably result in loss of precision. However, overflow of bits in the characteristic is always flagged. The program in Listing 1 will test any computer for the length of mantissa in its floating point representation and report it both in terms of bits and equivalent number of decimal digits. The largest integer that can be faithfully represented has a mantissa of all '1' bits, and is

equivalent to  $2^{\uparrow M I}$  if there are M bits in the mantissa. The program will also test the number of bits used for the characteristic. In this case the program will be interrupted at the occurrence of floating point overflow. If your computer does not support the TRAP (or the equivalent ON ERROR GOTO) command in line 210, then line 270 will never be reached. However, the last value of I printed before overflow occurs is the number of bits in the characteristics; the last value of X is a trifle greater than half the largest possible number for that machine. The largest possible number, when there are N bits in the characteristic and M bits in the mantissa, is  $2^{\uparrow(2\uparrow N - I)}$  multiplied by a fraction, very nearly unity, whose numerator contains M '1' bits and whose denominator contains a '1' bit followed by M '0' bits. With a 7-bit characteristic and a 32-bit mantissa, this is very nearly 1.70141183E+38. The hexadecimal representation may vary slightly among BASIC interpreters due to differences in characteristic biasing and in the way the sign bit is expressed. In Microsoft BASIC, the largest possible number has the hex value

\$FF7FFFFFFF. If your machine lets you alter a number in BASIC's variable table, via monitor or POKEs, you can enter the above value and return to BASIC to print its decimal equivalent.

Extended precision routines in assembly language are perfectly straightforward, rapid and effective; though they tend to get messy for multiplication and especially so for division. Nevertheless, if extensive calculations are required, this method is recommended as being the fastest. It is possible to achieve workable results in BASIC by the procedure given here, in which a large number is broken up and arithmetic operations carried out on the separated parts, with the results combined at the end. If it is necessary for the final result to have greater precision than is available in BASIC, then it will have to be expressed in parts, but this is entirely feasible.

In brief, a large number is expressed as  $(M \cdot 10^{\uparrow 6} + T \cdot 10^{\uparrow 3} + U)$ , where M is the coefficient of the millions place, T the coefficient of the thousands place, and U the units. Obviously, this scheme can be extended to both larger and smaller numbers by choosing the proper powers of ten as multipliers. In

```

10 REM PROGRAM TO MEASURE MAXIMUM PRECISION AND MAGNITUDE OF
20 REM REAL NUMBERS> WHEN ADDING 1 TO OR SUBTRACTING 1 FROM A GIVEN
30 REM NUMBER FAILS TO GIVE A RESULT 1 DIFFERENT FROM THE STARTING
40 REM NUMBER, THE LIMIT OF PRECISION HAS BEEN REACHED. WHEN OVERFLOW
50 REM ERROR OCCURS, THE MAXIMUM MAGNITUDE HAS BEEN REACHED.
100 FOR I=1 TO 100
110 B=2↑I
120 A=B-1
130 C=B+1
140 PRINT I;C-B;B-A;B
150 IF C-B<>1 OR B-A<>1 THEN 170
160 NEXT I
170 N=I*LOG(2)/LOG(10)
180 N=INT(10*N)/10
190 PRINT:PRINT I;"BITS IN MANTISSA":PRINT
200 PRINT N;"DECIMAL DIGITS OF PRECISION":PRINT
210 TRAP 270
220 FOR I=1 TO 100
230 N=2↑I
240 X=2↑(N-2)
250 PRINT I;N-1;X
260 NEXT I
270 PRINT I-1;"BITS IN CHARACTERISTIC"
280 END

```

the present case, M, T, and U are not larger than 3 digits each for any number up to 999,999,999. While this number can be expressed without loss of precision in 9.5 digit BASIC, the product of two such numbers will have 18 digits and 8 or 9 of the least significant digits will be lost. Addition and subtraction are done by parts, with proper attention to carry (if  $U_1 = 843$  and  $U_2 = 417$ , then  $U_1 + U_2 = 1260$ . I.e., the result has  $U = 260$  and there is a carry of 1 into T). Multiplication follows the rule for multiplication of polynomials:

$$(M_1 * 10^6 + T_1 * 10^3 + U_1) * (M_2 * 10^6 + T_2 * 10^3 + U_2) = M_1 * M_2 * 10^{12} + (M_1 * T_2 + M_2 * T_1) * 10^9 + (M_1 * U_2 + M_2 * U_1 + T_1 * T_2) * 10^6 + (T_1 * U_2 + T_2 * U_1) * 10^3 + U_1 * U_2$$

Of course, the powers of ten are not explicitly entered, or you have gained nothing. Rather, the calculations are done on the coefficients, and the partial products carried along. If combining the terms at the end after multiplying by the appropriate powers of ten gives adequate precision, the results can simply be multiplied out and printed in the usual way. But if the extra precision thus gained is wanted in the result, the numbers must be converted using STR\$ and the character strings which result are then concatenated to

give the final result. In order to take account of carry correctly, addition, subtraction and multiplication must proceed from right to left; while division is calculated from left to right.

A practical application of this method is illustrated by the program in Listing 2. Although there are many calendar programs available, this is the only one I know of for calculating the date of the Jewish New Year. The Jewish calendar is a lunar calendar, with months of length alternately 29 and 30 days, so that the first of every month falls within a day or so of a new moon. Twelve such months total only 354 days, about 11.25 less than a solar year. In order to avoid the large errors that would arise from a deficit of 11 days per year, seven leap years of 13 months each are distributed over a 19 year cycle. The difference between 19 solar years and 235 lunar months is only 1.44907 hours. The length of the year may be adjusted by plus or minus one day in order that the New Year will not fall on Sunday, Wednesday or Friday. These small adjustments over the years also compensate for the extra 1.449 hours mentioned above. For further information and for derivation of the method and formulas used see two articles by Louis A. Resnikoff in *Scripta Mathematica* 9,191-195, 274-277(1943). The only part of the calculation that requires extended

precision arithmetic is evaluation of the following division:

$$(31524 + (235 * C + 12 * m + 13 * n) * 765433) / 181440,$$

where C is an integer with a value about 300 at the present time, and m and n are small integers. The quotient is not required here, but the remainder points to the day of the week on which the New Year occurs through a table. This division cannot be done without error in 9.5 digit BASIC. It is programmed in lines 2000-2330. Although the quotient is not required, as noted above, it is calculated in the subroutine for illustrative purposes.

The program is written in "standard" BASIC and should run with little or no change on most microcomputers. To use the program, simply enter the common or calendar year in response to the prompting message. The results are printed to the screen in the following form:

ENTER CIVIL YEAR?

1984

CIVIL YEAR = 1984

JEWISH YEAR = 5745

NEW YEAR'S DAY IS ON

THU SEP 27

ORDINARY YEAR 354 DAYS

FIRST DAY OF PASSOVER

IS ON APR 6 1985

The program gives not only the date of the New Year, but also tells whether the year is an ordinary year or a leap year, the exact number of days in the year, and the date of the first day of Passover.

As the accompanying listing illustrates, it is relatively direct to write programs in BASIC that will handle arithmetic calculations with any desired degree of precision, by breaking the problem into smaller parts and doing the calculations for each part separately.

The program gives not only the date of the New Year, but also tells whether the year is an ordinary year or a leap year, the exact number of days in the year, and the date of the first day of Passover.

To construct a calendar for any given year it is necessary to know the arrangement of months in the Jewish year. The transliteration of Hebrew characters is apparently not fully agreed on; I have used a scheme that seems to be widely accepted. In an ordinary year of 354 days the months are as follows: Tishri, 30 days; Heshvan, 29 days; Kislev, 30 days; Tebeth, 29 days; Shebat, 30 days; Adar, 29 days; Nisan, 30 days; Iyar, 29 days; Sivan, 30 days; Tammuz, 29 days; Ab, 30 days; and Elul, 29 days. Some of the important holidays are New Year, Tishri 1; Yom Kippur, Tishri 10; Hanukkah, Kislev 25-Tebeth 2 or 3 (see below on the length of Kislev); and Passover, Nisan 15-21. There are three possible adjustments to this calendar. If the year is a leap year, then a thirteenth month of 29 days called Adar Sheni, or Second Adar, is interpolated between Adar (now First Adar) and Nisan. First Adar is increased to 30 days. If the length of the year is 353 or 383 days [defective year], Kislev is shortened to 29 days. If the length of the year is 355 or 385 days [full year], then Heshvan is increased to 30 days.

For the current year of 1983-84 [Jewish year 5744], the program gives the date of the New Year as September 8, 1983 and the length of the year as 385 days (both a leap year and a full year). The correspondence with the civil calendar can be tabulated as follows:

Jewish date	Civil date
Tishri 1, 5744	Sep 8, 1983
Heshvan 1	Oct 8
Kislev 1	Nov 7
Tebeth 1	Dec 7
Shebat 1	Jan 5, 1984
First Adar 1	Feb 4
Second Adar	1 Mar 5
Nisan 1	Apr 3
Iyar 1	May 3
Sivan 1	Jun 1
Tammuz 1	Jul 1
Ab 1	Jul 30
Elul 1	Aug 29
Tishri 1, 5745	Sep 27

As the accompanying listing illustrates, it is relatively direct to write programs in BASIC that will handle arithmetic calculations with any desired degree of precision, by breaking the problem into smaller parts and doing the calculations for each part separately.

```

10 REM PROGRAM TO CALCULATE DATE OF JEWISH NEW YEAR
20 REM METHOD BASED ON NOTES BY L.A. RESNIKOFF
30 REM "Scripta Mathematica" 9,191-195,274-277(1943).
40 REM WRITTEN BY Rolf B. Johannesen
50 REM LAST REVISION 20 MAR 1984
60 DIM RC(7,4),RT(6,4)
65 B$=CHR$(32)
70 FOR R1=1 TO 4
80 READ RN
90 FOR R2= 1 TO RN
100 READ RC(R2,R1):NEXT R2
110 FOR R2 =1 TO 6
120 READ RT(R2,R1):NEXT R2:NEXT R1
130 PRINT "ENTER CIVIL YEAR"
140 INPUT YR
150 JY=YR+3761
160 REM FIND NO. OF 19-YEAR CYCLE
170 C=INT((JY-1)/19)
180 REM AND YEAR NO. IN THAT CYCLE
190 R=JY-19*C
230 REM SET YEAR TYPE AS ORDINARY
240 REM CHANGE LATER IF A LEAP YEAR
250 Y$="ORDINARY":YL=354
260 FOR K=1 TO 4:FOR J=1 TO 7
270 IF R=RC(J,K) THEN 290
280 NEXT J : NEXT K
290 ON K GOTO 400,400,400,300
300 REM LEAP YEAR (13 MONTHS)
310 Y$="LEAP":YL=384
320 N=INT((R-1)/3)
330 GOSUB 2010 : GOTO 420
400 REM ORDINARY YEAR (12 MONTHS)
410 GOSUB 2000
420 FOR RR=1 TO 6
430 IF FR<=RT(RR,K) THEN 500
440 NEXT RR
450 IF FR<=174959 THEN YT=1:GOTO 810
460 J=9:YT=-1:GOTO 620
500 ON RR GOTO 550,600,650,700,750,800
550 YT=-1:GOTO 610
600 YT=1
610 J=2
620 D$="MON":GOTO 1000
650 YT=0:J=3
660 D$="TUE":GOTO 1000
700 YT=-INT(K/4)
710 GOTO 760
750 YT=1
760 J=5:D$="THU"
770 GOTO 1000
800 YT=-1
810 J=7:D$="SAT"
1000 REM NOW WE HAVE DAY OF WEEK
1010 REM NEXT CALCULATE DATE
1020 Q=(-332844+1565*C+282084*M-483349*N+FR)/25920
1030 IQ=22+INT(YR/100)-INT(YR/400)-INT(Q+.75)+J
1040 YL=YL+YT
1050 IF IQ> 30 THEN 1090
1060 M$="SEP"
1070 DT=IQ
1080 GOTO 1105
1090 M$="OCT"
1100 DT=IQ-30
1105 GOSUB 3100
1110 PRINT:PRINT:PRINT
1120 PRINT(" CIVIL YEAR = "+STR$(YR))
1130 PRINT:PRINT(" JEWISH YEAR = "+STR$(JY))
1140 PRINT:PRINT(" NEW YEAR'S DAY IS ON"
1150 P$=B$+B$+D$+B$+M$+B$+STR$(DT)
1160 PRINT:PRINT P$
1170 PRINT:PRINT(Y$+B$+"YEAR "+B$+B$);

```

**\$uch A Deal** inc.

**LEGEND**

PERIPHERAL PRODUCTS

**DOT MATRIX PRINTERS**

80 CPS .....	\$239
100 CPS .....	\$259
120 CPS .....	\$299
150 CPS .....	\$349

**CARDCO INTERFACES**

Economy Printer .....	\$47
Graphic Printer .....	\$77

**SPECIALS**

12 Inch Amber Monitor  
**\$89**  
Concorde Disk Drive  
**\$297**

**C64 SOFTWARE SPECIALS**

Epyx Summer Games .....	\$25
Sublogic Flight Simulator II ..	\$37
Screenplay Pogo Joe .....	\$49
Access Beachhead .....	\$23
Infocom Sorcerer .....	\$33
Continental Home Acct. ....	\$47
Timeworks Word Writer .....	\$39
Timeworks Data Manager II ..	\$39
Commodore Magic Desk ...	\$55
Microware Clone Machine ..	\$39
Blue Sky Super Copy .....	\$29
Handic CalcResult Adv'd. ...	\$75
Professional Word Pro 3 plus Spellright .....	\$69
Synapse Zaxxon .....	\$28
Spinnaker Kindercomp .....	\$19
Datasoft Dallas Quest .....	\$25
Dynatech Codewriter .....	\$69

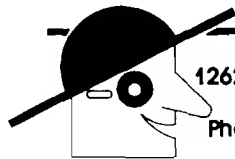

12629 N. Tatum Blvd.  
Suite 138  
Phoenix, AZ 85032

**CALL TOLL FREE 1-800-431-8697**  
For Customer Service Call:  
602-957-3619

ORDERING & TERMS: Send cashier check, money order, personal/company checks allow 3 weeks bank clearance. VISA/MasterCard accepted. Provide phone number with order. SHIPPING: add \$4.00 for first three pieces, add \$1.00 each additional piece. Hardware add \$10.00. Prices are for cash. VISA and MasterCard add 3%. Prices subject to change without notice. All products subject to availability from manufacturers and/or suppliers. All prices in U.S. dollars.

```
1180 PRINT (STR$(YL)+B$+"DAYS")
1182 PRINT
1185 PRINT " FIRST DAY OF PASSOVER"
1186 PRINT:PRINT (" IS ON "+PM$+STR$(PD)+STR$(PY))
1190 PRINT : PRINT : PRINT "AGAIN";
1200 INPUT A$
1210 IF ASC(A$)=89 THEN 130
1220 END
2000 N=INT(R/3)
2010 M=R-N-1
2020 REM SUBROUTINE TO FORM AN 11 DIGIT PRODUCT
2030 REM BY MULTIPLYING A 6 DIGIT * A 5 DIGIT NUMBER
2040 REM AND DIVIDING BY A 6 DIGIT NUMBER TO GET
2050 REM A QUOTIENT AND REMAINDER WITH NO LOSS OF PRECISION
2060 REM Tn = THOUSANDS; Un = UNITS; MI = MILLIONS
2070 PR=235*C+12*M+13*N
2080 T1=INT(PR/1000)
2090 U1=PR-1000*T1
2100 T2=765:U2=433
2110 MI=T1*T2
2120 TH=T1*U2+T2*U1
2130 U=U1*U2+31524
2140 U=U+1000*(TH-1000*INT(TH/1000))
2150 MI=MI+INT(TH/1000)+INT(U/1E6)
2160 U=U-1E6*INT(U/1E6)
2170 REM QUOTIENT NOT NEEDED FOR THIS PROBLEM
2180 REM BUT CARRIED THROUGH FOR ILLUSTRATION
2190 QU=0
2200 DV=181440
2210 FOR I=1 TO 6
2220 TD=INT(MI/DV)
2230 QU=10*QU+TD
2240 FR=MI-TD*DV
2250 TU=INT(U/10*(6-I))
2260 MI=FR*10+TU
2270 U=U-TU*10*(6-I)
2280 U=INT(U+.5)
2290 NEXT I
2300 TD=INT(MI/DV)
2310 QU=10*QU+TD
2320 FR=MI-TD*DV
2330 RETURN
2900 REM DATA STATEMENTS DIVISIBLE BY 20 GIVE YEARS IN CYCLE
2910 REM WITH ATTRIBUTES LISTED IMMEDIATELY PRECEDING
2920 REM ALTERNATE DATA STATEMENTS GIVE NUMERATORS OF
2930 FRACTION OF A WEEK
2940 REM DENOMINATOR OF FRACTION ALWAYS 181440
2990 REM ORDINARY YEARS THROUGH 3050
2995 REM YEARS FOLLOWING AN ORDINARY YEAR NEXT
3000 DATA 5,2,5,10,13,16
3010 DATA 9923,45359,61763,113603,123119,139523
3015 REM YEARS PRECEDING AN ORDINARY YEAR NEXT
3020 DATA 5,1,4,9,12,15
3030 DATA 9923,42708,61763,113603,123119,130007
3035 REM YEARS BETWEEN TWO LEAP YEARS NEXT
3040 DATA 2,7,18
3050 DATA 9923,42708,61763,113603,123119,139523
3055 REM LEAP YEARS NEXT
3060 DATA 7,3,6,8,11,14,17,19
3070 DATA 22090,45359,71279,90334,123119,151690
3100 SU=344:PY=YR+1
3110 IF 400*INT(PY/400)=PY THEN 3140
3120 IF 100*INT(PY/100)=PY THEN 3150
3130 IF 4*INT(PY/4) < PY THEN 3150
3140 SU=345
3150 PD=YL+IQ-SU
3160 IF PD>31 THEN 3190
3170 PM$="MAR"
3180 RETURN
3190 PM$="APR":PD=PD-31
3200 RETURN
```

**MICRO**

# THE COMPUTERIST BOOKCART

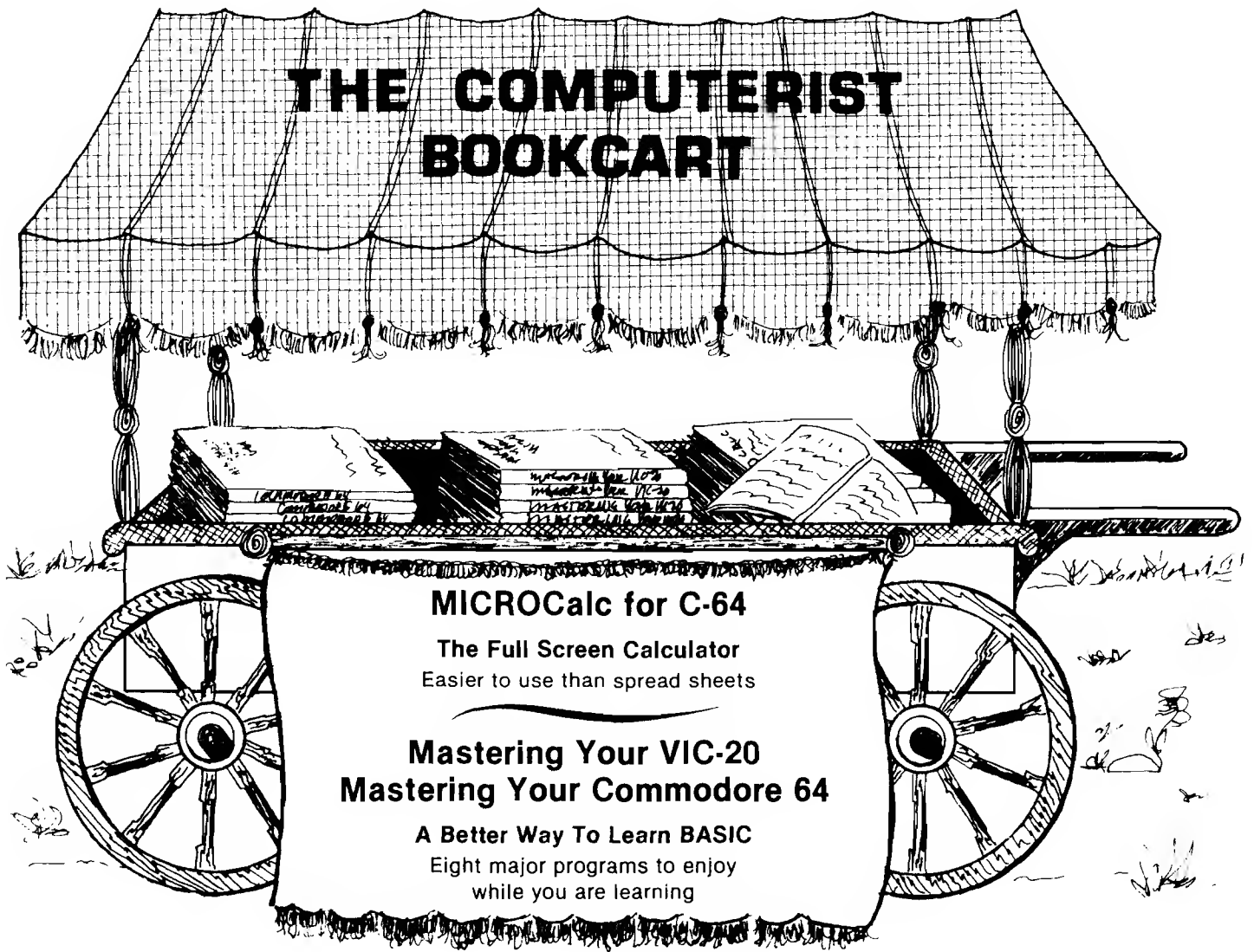

## MICROCalc for C-64

The Full Screen Calculator  
Easier to use than spread sheets

## Mastering Your VIC-20 Mastering Your Commodore 64

A Better Way To Learn BASIC  
Eight major programs to enjoy  
while you are learning

### Mastering Your VIC-20 Mastering Your Commodore 64

The 8 programs, "run-ready" on disk (C-64) or tape (VIC-20) and explained in the 160-192 page book, each demonstrate important concepts of BASIC while providing useful, enjoyable software. Programs include:

- Player — compose songs from your keyboard, save, load and edit for perfect music
- MicroCalc — display calculation program that make even complex operations easy
- Master — a one or two person guessing game
- Clock — character graphics for a digital clock

VIC-20 with tape & book ..... **just \$19.95**  
C-64 with disk & book (avail. Sept.) ..... **just \$19.95**

Look for us at the  
International Software Show  
Toronto, September 20-23

### MICROCalc for C-64

This on-screen calculator comes with diskette and 48-page manual offering a wide variety of useful screens, and a great way to learn BASIC expressions if you don't already know them.

- Unlimited calculation length & complexity
- Screens can be linked and saved on disk/cassette
- Build a library of customized screens
- Provide formatted printer output

Diskette & 48-page manual ..... **just \$29.95**

### For the Freshest Books, Buy Direct!

- No prehandled books with bent corners
- Books come direct to your door
- No time wasted searching store to store
- 24 hours from order receipt to shipment
- No shipping/handling charges
- No sales tax (except 5% MA res.)
- Check, MO, VISA/MC accepted (prepaid only)

The Computerist Bookcart  
P.O. Box 6502, Chelmsford, MA 01824  
For faster service, phone: 617/256 - 3649.

# HILISTER - *A Study and Teaching Aid*

(Part 2)



**by J. Morris Prosser**

---

**Move easily within your programs and highlight parts of text or listings for emphasis or clarity.**

---

Part 1 of this article described the HILISTER program and included the highlighter portion of the assembly listing. This part will include the remainder of the listing and will explain how to interface it to the first part.

If you have an assembler, the source code for the first part should be loaded, then the second part should be added. You may prefer to enter the second part as a separate source file, then append it to the first part. If you do that, you will not be able to assemble it separately, since it is not complete in itself. In either case, UPDO and DOWNDO should be removed from the list of equates, since they are internal labels in the second part of the source. At label LISTER, change the operation code mnemonic from RTS to CLD, so that execution falls through to the

second part of the program. Once the code has been entered and these changes have been made, the code can be assembled and the source and object code saved as HILISTER. The program should now be complete.

If you are entering the code without an assembler, it is best to enter the second part of the code separately. It should then be saved:

```
BSAVE HILISTER2,A$80D0,L$540
```

In the process of entering the code, it is a good idea to stop every now and then (say every screenful) and save what you have entered to disk, using the same command as shown above. If you now BLOAD HILISTER1 and BLOAD HILISTER2, you will be ready to make the changes necessary to integrate the two sections. Go to the

monitor (CALL -151) and enter 8062.8063, remembering that a carriage return is required after each entry. You should see 8062- 58 FF if the program has been entered correctly. Now enter 8062:83 83. Next enter 8087.8088. You should see 8087- 58 FF. Enter 8087:65 83. One more change is needed - enter 80CF, and you should see 80CF- 60. Enter 80CF:D8, and you are finished. Save the program back to your disk:

```
BSAVE HILISTER,A$8000,L$610
```

You should be able to use the program now by entering BRUN HILISTER.

*NOTE: In last month's listing of hilister (part 1) line 8008 should read*  
~~8008~~ A9 1B LDA BEGIN  
*line 8010 should read*  
~~8010~~ A9 80 LDA BEGIN

\* Determine type of listing and  
 \* branch accordingly. If A =  
 \* #188 = Applesoft  
 \* \$ = monitor  
 \* C = Catalog  
 \* B = setup to Begin  
 \* E = End of listing  
 \* anything else is error

```
80D0 C9 BC      CMP #188
80D2 D0 08      BNE NOTLIST
80D4 85 1A      STA LSTFLG
80D6 20 0A 81   JSR OUTSET
80D9 4C 9D 81   JMP LISTST
80DC C9 24      NOTLIST CMP #'$'
80DE D0 08      BNE NOTLIST1
80E0 85 F9      STA MEMFLG
80E2 20 0A 81   JSR OUTSET
80E5 4C 4B 84   JMP MEMLST
80E8 C9 43      NOTLIST1 CMP #'C'
80EA D0 08      BNE NOTC
80EC 85 1D      STA CATFLG
80EE 20 0A 81   JSR OUTSET
80F1 4C 76 85   JMP CTLG
80F4 C9 42      NOTC   CMP #'B'
80F6 D0 06      BNE NOTB
80F8 20 0A 81   JSR OUTSET
80FB 4C D0 03   JMP BASIC
80FE C9 45      NOTB   CMP #'E'
8100 D0 05      BNE ERROR
8102 85 1A      STA LSTFLG
8104 4C 2F 82   JMP ENDLST
8107 4C C9 DE   ERROR  JMP SYNERR
```

\* Detour character output,  
 \* TELLDOS to make DOS happy, and  
 \* Set/test buffer pointers

```
810A A0 56      OUTSET LDY #< OUTST
810C 84 36      STY CSWL
810E A0 81      LDY #> OUTST
8110 84 37      STY CSWL+1
8112 20 EA 03   JSR TELLDOS
8115 A0 00      LDY #< BUFLE
8117 84 FA      STY BUFST
8119 A0 40      LDY #> BUFLE
811B 84 FB      STY BUFST+1
811D A4 1A      LDY LSTFLG
811F F0 09      BEQ BUFOK
8121 A4 B0      LDY $B0
8123 C8        INY
8124 C4 FB      CPY BUFST+1
8126 90 02      BCC BUFOK
8128 84 FB      STY BUFST+1
```

\* Set up to fill buffer with carriage returns  
 \* Set screen start and end of listing area

```
812A A4 FA      BUFOK  LDY BUFST
812C 84 3C      STY A1L
812E 84 FC      STY SCRST
8130 C8        INY
8131 84 42      STY A4L
8133 A4 FB      LDY BUFST+1
8135 84 3D      STY A1L+1
8137 84 43      STY A4L+1
8139 84 FD      STY SCRST+1
813B 38        SEC
813C A9 FF      LDA #< START-1
813E 85 3E      STA A2L
8140 E9 18      SBC #24
8142 85 FE      STA LSTEND
8144 A9 7F      LDA #> START-1
8146 85 3F      STA A2L+1
8148 E9 00      SBC #0
```

```
814A 85 FF      STA LSTEND+1
814C A9 8D      LDA #8D
814E A0 00      LDY #0
8150 91 FA      STA (BUFST),Y
8152 20 2C FE   JSR MOVE
8155 60        RTS
```

\* Character output detour  
 \* Print to screen and update  
 \* and test buffer pointers

```
8156 84 07      OUTST  STY TEMPY
8158 20 F0 FD   JSR COUT1
815B A0 00      LDY #0
815D 91 FC      STA (SCRST),Y
815F 20 D8 83   JSR NXTLOC
8162 B0 03      BCS TOOLONG
8164 A4 07      LDY TEMPY
8166 60        RTS
```

\* Too Long - ring bell and show last lines  
 \* Get keyboard to determine what to do next

```
8167 20 3A FF   TOOLONG JSR BELL
816A 20 83 82   JSR PRTPSCRN
816D A0 00      LDY #0
816F B9 A0 85   MSGLP  LDA TOOLNG,Y
8172 F0 06      BEQ GETREQ
8174 20 F0 FD   JSR COUT1
8177 C8        INY
8178 D0 F5      BNE MSGLP
817A 2C 00 C0   GETREQ BIT KBD
817D 10 FB      BPL GETREQ
817F AD 00 C0   LDA KBD
8182 2C 10 C0   BIT KBDSTRB
8185 C9 8D      CMP #8D
8187 D0 09      BNE ESCCHK
8189 20 83 82   JSR PRTPSCRN
```

# TASK USERS

TIM  
 AIM  
 SYM  
 KIM

HDE continues to support the TIM, AIM, SYM and KIM with:

- Mini Disk Systems  
40/80 Track, S/D Sided
- Expansion Backplanes, RAM, ROM, Prototyping, Serial and Parallel Boards
- Software  
Disk Basic, Forth, Disk Assembler, Disassembler, etc.

In addition to our own advanced 65XX development and industrial systems.

**HDE** inc.

Call or write for our catalog  
 P.O. Box 339  
 Johnsonburg, NJ 07846  
 (201) 362-6574

```

818C 20 03 84      JSR SCRNPRT
818F 4C 9A 82      JMP GETCMD
8192 C9 9B      ESCCHK  CMP #$9B
8194 D0 E4      BNE GETREQ
8196 20 58 FC      JSR HOME
8199 4C D0 03      JMP BASIC
*
* Applesoft list
*
819C 60      LRTN  RTS
819D A2 FF      LISTST LDX #$FF
819F 20 B1 00      JSR CHRGET
*
* Replacement for Applesoft LIST routine
*
81A2 90 0A      LIST  BCC LIST1
81A4 F0 08      BEQ LIST1
81A6 C9 C9      CMP #$C9
81A8 F0 04      BEQ LIST1
81AA C9 2C      CMP #$2C
81AC D0 EE      BNE LRTN
81AE 20 0C DA      LIST1 JSR LINGET
81B1 20 1A D6      JSR FNDLIN
81B4 20 B7 00      JSR CHRGET
81B7 F0 10      BEQ LIST3
81B9 C9 C9      CMP #$C9
81BB F0 04      BEQ LIST2
81BD C9 2C      CMP #$2C
81BF D0 DB      BNE LRTN
81C1 20 B1 00      LIST2 JSR CHRGET
81C4 20 0C DA      JSR LINGET
81C7 D0 D3      BNE LRTN
81C9 68      LIST3 PLA
81CA 68      PLA
81CB A5 50      LDA LINNUM
81CD 05 51      ORA LINNUM+1
81CF D0 06      BNE LIST4
81D1 A9 FF      LDA #$FF
81D3 85 50      STA LINNUM
81D5 85 51      STA LINNUM+1
81D7 A0 01      LIST4 LDY #$01
81D9 B1 9B      LDA (LOWTR),Y
81DB F0 4D      BEQ LIST10
81DD 20 D0 84      JSR ISCNTC
81E0 20 FB DA      JSR CRDO
81E3 C8      INY
81E4 B1 9B      LDA (LOWTR),Y
81E6 AA      TAX
81E7 C8      INY
81E8 B1 9B      LDA (LOWTR),Y
81EA C5 51      CMP LINNUM+1
81EC D0 04      BNE LIST5
81EE E4 50      CPX LINNUM
81F0 F0 02      BEQ LIST6
81F2 B0 36      LIST5 BCS LIST10
81F4 84 85      LIST6 STY FORPNT
81F6 20 24 ED      JSR LINPRT
81F9 A9 20      LDA #$20
81FB A4 85      LIST7 LDY FORPNT
81FD 29 7F      AND #$7F
81FF 20 5C DB      LIST8 JSR OUTDO
8202 A5 24      LDA CH
8204 C9 21      CMP #$21
8206 90 10      BCC LIST9
8208 20 FB DA      JSR CRDO
820B A9 05      LDA #5
820D 85 1B      STA COUNT
820F A9 A0      LIST9 LDA #$A0
8211 20 5C DB      JSR OUTDO
8214 C6 1B      DEC COUNT

```

```

8216 D0 F7      BNE LSTLOOP
8218 C8      LIST9 INY
8219 B1 9B      LDA (LOWTR),Y
821B D0 33      BNE LIST13
821D A8      TAY
821E B1 9B      LDA (LOWTR),Y
8220 AA      TAX
8221 C8      INY
8222 B1 9B      LDA (LOWTR),Y
8224 86 9B      STX LOWTR
8226 85 9C      STA LOWTR+1
8228 D0 AD      BNE LIST4
822A A9 0D      LIST10 LDA #$0D
822C 20 5C DB      JSR OUTDO
*
* End of List processing
*
822F 20 83 82      ENDLST JSR PRTPSCRN
8232 20 03 84      JSR SCRNPRT
8235 20 3A FF      JSR BELL
8238 A0 00      LDY #0
823A B9 EC 85      MSGLP1 LDA ENDMMSG,Y
823D F0 06      BEQ LISTEND
823F 20 F0 FD      JSR COUT1
8242 C8      INY
8243 D0 F5      BNE MSGLP1
8245 4C 9A 82      LISTEND JMP GETCMD
8248 C8      LIST11 INY
8249 D0 02      BNE LIST12
824B E6 9E      INC DSCTMP+1
824D B1 9D      LIST12 LDA (DSCTMP),Y
824F 60      RTS
8250 10 AD      LIST13 BPL LIST8
8252 38      SEC
8253 E9 7F      SBC #$7F
8255 AA      TAX
8256 84 85      STY FORPNT
8258 A0 D0      LDY #$D0
825A 84 9D      STY DSCTMP
825C A0 CF      LDY #$CF
825E 84 9E      STY DSCTMP+1
8260 A0 FF      LDY #$FF
8262 CA      LIST14 DEX
8263 F0 07      BEQ LIST16
8265 20 48 82      LIST15 JSR LIST11
8268 10 FB      BPL LIST15
826A 30 F6      BMI LIST14
826C A9 20      LIST16 LDA #$20
826E 20 5C DB      JSR OUTDO
8271 20 48 82      LIST17 JSR LIST11
8274 30 05      BMI LIST18
8276 20 5C DB      JSR OUTDO
8279 D0 F6      BNE LIST17
827B 20 5C DB      LIST18 JSR OUTDO
827E A9 20      LDA #$20
8280 4C FB 81      JMP LIST7
*
* Set up to print last lines of
* listing to screen
8283 20 BC 83      PRTPSCRN JSR PGBACK
8286 A5 FC      LDA SCRST
8288 85 FE      STA LSTEND
828A A5 FD      LDA SCRST+1
828C 85 FF      STA LSTEND+1
828E A9 F0      LDA #< COUT1
8290 85 36      STA CSWL
8292 A9 FD      LDA #> COUT1
8294 85 37      STA CSWL+1
8296 20 EA 03      JSR TELLDOS
8299 60      RTS

```

```

*
* Get keyboard command
*
829A 2C 00 C0 GETCMD BIT KBD
829D 10 FB BPL GETCMD
829F AD 00 C0 LDA KBD
82A2 2C 10 C0 BIT KBDSTRB
82A5 C9 A0 CMP #A0
82A7 D0 10 BNE NOTSPC
82A9 A5 1E LDA DIRFLG
82AB 30 06 BMI DOWN
82AD 20 65 83 JSR UPDO
82B0 4C 9A 82 JMP GETCMD
82B3 20 83 83 DOWN JSR DOWNDO
82B6 4C 9A 82 JMP GETCMD
82B9 C9 88 NOTSPC CMP #88
82BB D0 06 BNE NOTDN
82BD 20 4E 83 JSR SCRLDN
82C0 4C 9A 82 JMP GETCMD
82C3 C9 95 NOTDN CMP #95
82C5 D0 06 BNE NOTUP
82C7 20 37 83 JSR SCRLUP
82CA 4C 9A 82 JMP GETCMD
82CD C9 9B NOTUP CMP #9B
82CF D0 03 BNE NOTOUT
82D1 4C D0 03 JMP BASIC
82D4 C9 AB NOTOUT CMP #AB
82D6 D0 06 BNE NOTAB
82D8 20 A0 83 JSR PGFWD
82DB 4C 9A 82 JMP GETCMD
82DE C9 BB NOTAB CMP #BB
82E0 D0 06 BNE NOTBB
82E2 20 A0 83 JSR PGFWD
82E5 4C 9A 82 JMP GETCMD
82E8 C9 AD NOTBB CMP #AD
82EA D0 06 BNE NOTAD
82EC 20 BC 83 JSR PGBAK
82EF 4C 9A 82 JMP GETCMD
82F2 C9 BD NOTAD CMP #BD
82F4 D0 06 BNE NOTBD
82F6 20 BC 83 JSR PGBAK
82F9 4C 9A 82 JMP GETCMD
82FC C9 A6 NOTBD CMP #A6
82FE D0 06 BNE NOTA6
8300 20 2E 80 JSR HILITER1
8303 4C 9A 82 JMP GETCMD
8306 C9 C2 NOTA6 CMP #C2
8308 D0 0E BNE NOTC2
830A A5 FA LDA BUFST
830C 85 FC STA SCRST
830E A5 FB LDA BUFST+1
8310 85 FD STA SCRST+1
8312 20 03 84 JSR SCRNPRT
8315 4C 9A 82 JMP GETCMD
8318 C9 C5 NOTC2 CMP #C5
831A F0 03 BEQ C5
831C 4C 9A 82 JMP GETCMD
831F A5 FE C5 LDA LSTEND
8321 85 FC STA SCRST
8323 A5 FF LDA LSTEND+1
8325 85 FD STA SCRST+1
8327 20 03 84 JSR SCRNPRT
832A 4C 9A 82 JMP GETCMD
*
* Look for keypress to stop scroll
*
832D 2C 00 C0 KBDCHK BIT KBD
8330 10 04 BPL NOKEY
8332 2C 10 C0 BIT KBDSTRB
8335 38 SEC

```

```

8336 60 NOKEY RTS
*
* Scroll up routine
*
8337 20 D8 83 SCRLUP JSR NXTLOC
833A 90 09 BCC SCRLUP2
833C 20 3A FF JSR BELL
833F 60 RTS
8340 20 D8 83 SCRLUP1 JSR NXTLOC
8343 B0 08 BCS UPRTN
8345 20 6E 83 SCRLUP2 JSR UPRTN
8348 20 2D 83 JSR KBDCHK
834B 90 F3 BCC SCRLUP1
834D 60 UPRTN RTS
*
* Scroll down routine
*
834E 20 EA 83 SCRLDN JSR LSTLOC
8351 90 09 BCC SCRLDN2
8353 20 3A FF JSR BELL
8356 60 RTS
8357 20 EA 83 SCRLDN1 JSR LSTLOC
835A B0 08 BCS DNRTN
835C 20 8C 83 SCRLDN2 JSR DWNOK
835F 20 2D 83 JSR KBDCHK
8362 90 F3 BCC SCRLDN1
8364 60 DNRTN RTS
*
* Scroll up one line
*
8365 20 D8 83 UPDO JSR NXTLOC
8368 90 04 BCC UPOK
836A 20 3A FF JSR BELL
836D 60 RTS
836E A0 00 UPOK LDY #0
8370 84 1E STY DIRFLG
8372 20 D8 83 JSR NXTLOC
8375 B1 FC UPLOOP LDA (SCRST),Y
8377 C9 8D CMP #8D
8379 F0 05 BEQ UPDONE
837B 20 D8 83 JSR NXTLOC
837E 90 F5 BCC UPLOOP
8380 4C 03 84 UPDONE JMP SCRNPRT
*
* Scroll down one line
*
8383 20 EA 83 DOWNDO JSR LSTLOC
8386 90 04 BCC DWNOK
8388 20 3A FF JSR BELL
838B 60 RTS
838C A0 00 DWNOK LDY #0
838E 84 1E STY DIRFLG
8390 C6 1E DEC DIRFLG
8392 B1 FC DWNLOOP LDA (SCRST),Y
8394 C9 8D CMP #8D
8396 F0 05 BEQ DWNDONE
8398 20 EA 83 JSR LSTLOC
839B 90 F5 BCC DWNLOOP
839D 4C 03 84 DWNDONE JMP SCRNPRT
*
* Page forward
*
83A0 20 D8 83 PGFWD JSR NXTLOC
83A3 90 04 BCC PGFOK
83A5 20 3A FF JSR BELL
83A8 60 RTS
83A9 A2 17 PGFOK LDY #23
83AB A0 00 LDY #0
83AD 20 D8 83 PGFLOOP JSR NXTLOC
83B0 B1 FC LDA (SCRST),Y

```

```

83B2 C9 8D      CMP #8D
83B4 D0 F7      BNE PGFLOOP
83B6 CA         DEX
83B7 D0 F4      BNE PGFLOOP
83B9 4C 03 84   JMP SCRNPRT
*
* Page backward
*
83BC 20 EA 83   PGBAK   JSR LSTLOC
83BF 90 04      BCC PGBOK
83C1 20 3A FF   JSR BELL
83C4 60         RTS
83C5 A2 17      PGBOK   LDY #23
83C7 A0 00      LDY #0
83C9 20 EA 83   PGBLOOP JSR LSTLOC
83CC B1 FC      LDA (SCRST),Y
83CE C9 8D      CMP #8D
83D0 D0 F7      BNE PGBLOOP
83D2 CA         DEX
83D3 D0 F4      BNE PGBLOOP
83D5 4C 03 84   JMP SCRNPRT
*
* Increment screen pointer
*
83D8 A5 FC      NXTLOC  LDA SCRST
83DA C5 FE      CMP LSTEND
83DC A5 FD      LDA SCRST+1
83DE E5 FF      SBC LSTEND+1
83E0 90 01      BCC NXTINC
83E2 60         RTS
83E3 E6 FC      NXTINC  INC SCRST
83E5 D0 02      BNE NXT1
83E7 E6 FD      INC SCRST+1
83E9 60         NXT1    RTS
*
* Decrement screen pointer
*
83EA A5 FA      LSTLOC  LDA BUFST
83EC C5 FC      CMP SCRST
83EE A5 FB      LDA BUFST+1
83F0 E5 FD      SBC SCRST+1
83F2 90 01      BCC LSTDEC
83F4 60         RTS
83F5 C6 FC      LSTDEC  DEC SCRST
83F7 A4 FC      LDY SCRST
83F9 C0 FF      CPY #FFF
83FB D0 02      BNE LSTRN
83FD C6 FD      DEC SCRST+1
83FF 18         LSTRN   CLC
8400 A0 00      LDY #0
8402 60         RTS
*
* Screen print routine
*
8403 A5 FC      SCRNPRT LDA SCRST
8405 85 3C      STA A1L
8407 A5 FD      LDA SCRST+1
8409 85 3D      STA A1L+1
840B A9 00      LDA #0
840D 85 24      STA CH
840F 85 25      STA CV
8411 20 22 FC   JSR VTAB
8414 A2 18      LDY #24
8416 A0 00      LOOP2   LDY #0
8418 20 BA FC   JSR NXTA1
841B B1 3C      LDA (A1L),Y
841D C9 8D      CMP #8D
841F D0 0A      BNE PRNT
8421 48         PHA
8422 20 9C FC   JSR CLREOL

```

```

8425 68         PLA
8426 CA         DEX
8427 D0 1C      BNE PRNT1
8429 18         CLC
842A 60         RTS
842B C9 8A      PRNT   CMP #8A
842D D0 16      BNE PRNT1
842F A5 24      LDA CH
8431 48         PHA
8432 20 9C FC   JSR CLREOL
8435 A9 8D      LDA #8D
8437 20 F0 FD   JSR COUT1
843A 20 9C FC   JSR CLREOL
843D 68         PLA
843E 85 24      STA CH
8440 CA         DEX
8441 D0 D3      BNE LOOP2
8443 18         CLC
8444 60         RTS
8445 20 F0 FD   PRNT1  JSR COUT1
8448 4C 16 84   JMP LOOP2
*
* Check for B8 (A/S token for "DEF")
* If found, replace with "DEF"
*
844B A0 FF      MEMLST LDY #FFF
844D C8         NEXT    INY
844E B9 00 02   LDA IN,Y
8451 F0 2F      BEQ B8OK
8453 C9 B8      CMP #B8
8455 D0 F6      BNE NEXT
8457 C8         NEXT1   INY
8458 B9 00 02   LDA IN,Y
845B D0 FA      BNE NEXT1
845D 99 02 02   STA IN+2,Y
8460 99 04 02   STA IN+4,Y
8463 88         NEXT2   DEY
8464 B9 00 02   LDA IN,Y
8467 99 02 02   STA IN+2,Y
846A C9 B8      CMP #B8
846C D0 F5      BNE NEXT2
846E A9 44      LDA #44
8470 99 00 02   STA IN,Y
8473 C8         INY
8474 A9 45      LDA #45
8476 99 00 02   STA IN,Y
8479 C8         INY
847A A9 46      LDA #46
847C 99 00 02   STA IN,Y
847F 4C 4B 84   JMP MEMLST
8482 A0 FF      B8OK   LDY #FFF
8484 C8         BACK   INY
8485 20 B1 00   JSR CHRGET
8488 F0 02      BEQ DONE
848A 09 80      ORA #80
848C 99 00 02   STA IN,Y
848F D0 F3      BNE BACK
8491 20 C7 FF   JSR ZMODE
8494 20 A7 FF   JSR GETNUM
8497 C9 A7      CMP #A7
8499 D0 0B      BNE NOTA7
849B 85 31      STA MODE
849D 20 A7 FF   JSR GETNUM
84A0 20 F2 84   JSR DUMP
84A3 4C 2F 82   JMP ENDLST
84A6 C9 39      NOTA7  CMP #39
84A8 F0 0A      BEQ DISASM
84AA C9 05      CMP #05
84AC F0 06      BEQ DISASM
84AE C9 01      CMP #01

```

```

84B0 D0 1B          BNE SNTX
84B2 85 1C          STA PLUSFLG
84B4 A5 3E          DISASM LDA A2L
84B6 85 3A          STA PCL
84B8 A5 3F          LDA A2L+1
84BA 85 3B          STA PCL+1
84BC A9 00          LDA #0
84BE 20 DD 84          JSR MONLIST
84C1 A5 1C          LDA PLUSFLG
84C3 F0 05          BEQ NEXT3
84C5 A9 00          LDA #0
84C7 20 DD 84          JSR MONLIST
84CA 4C 2F 82          NEXT3 JMP ENDLST
84CD 4C C9 DE          SNTX  JMP SYNERR

```

```

*
* Replacement for A/S cntrl-C check
*

```

```

84D0 AD 00 C0          ISCNTC LDA KBD
84D3 C9 83          CMP #83
84D5 D0 05          BNE CNTCRTN
84D7 68          PLA
84D8 68          PLA
84D9 4C 2F 82          JMP ENDLST
84DC 60          CNTCRTN RTS

```

```

*
* Replacement for monitor LIST2 routine
*

```

```

84DD 48          MONLIST PHA
84DE 20 D0 F8          JSR INSTDSP
84E1 20 53 F9          JSR PCADJ
84E4 85 3A          STA PCL
84E6 84 3B          STY PCL+1
84E8 20 D0 84          JSR ISCNTC
84EB 68          PLA
84EC 38          SEC
84ED E9 01          SBC #1
84EF D0 E6          BNE MONLIST
84F1 60          RTS

```

```

*
* Replacement for monitor XAM routine
*

```

```

84F2 20 C7 FF          DUMP  JSR ZMODE
84F5 88          DEY
84F6 D0 04          BNE FIXA3
84F8 A5 3C          LDA A1L
84FA 09 07          ORA #807
84FC 85 3E          STA A2L
84FE A5 3D          LDA A1L+1
8500 85 3F          STA A2L+1
8502 A4 3D          FIXA3 LDY A1L+1
8504 A6 3C          LDX A1L
8506 86 40          STX A3L
8508 84 41          STY A3L+1
850A 20 CA 84          JSR ISCNTC
850D A9 8D          LDA #88D
850F 20 ED FD          JSR COUT
8512 20 40 F9          JSR PRNTYX
8515 A0 00          LDY #800
8517 A9 AD          LDA #8AD
8519 20 ED FD          JSR COUT
851C A9 A0          HEXOUT LDA #8A0
851E 20 ED FD          JSR COUT
8521 B1 3C          LDA (A1L),Y
8523 20 DA FD          JSR PRBYTE
8526 20 BA FC          JSR NXTA1
8529 B0 06          BCS ASCOUT
852B A5 3C          LDA A1L
852D 29 07          AND #807
852F D0 E5          BNE HEXOUT
8531 20 31 85          JSR ASCOUT

```

```

8534 4C FC 84          JMP FIXA3
8537 A9 A0          ASCOUT LDA #8A0
8539 20 ED FD          JSR COUT
853C A9 1E          LDA #81E
853E C5 24          CMP $24
8540 B0 EF          BCS ASCOUT
8542 A0 00          LDY #800
8544 A9 07          LDA #807
8546 25 40          AND A3L
8548 49 FF          EOR #8FF
854A 18          CLC
854B 69 08          ADC #808
854D 48          GETNXT PHA
854E B1 40          LDA (A3L),Y
8550 29 7F          AND #87F
8552 C9 20          CMP #820
8554 90 FE          BCC SPCOUT
8556 09 80          ORA #880
8558 D0 FC          BNE PRINT
855A A9 A0          SPCOUT LDA #8A0
855C 20 ED FD          PRINT JSR COUT
855F A5 40          LDA A3L
8561 C5 3E          CMP A2L
8563 A5 41          LDA A3L+1
8565 E5 3F          SBC A2L+1
8567 E6 40          INC A3L
8569 D0 FC          BNE INCEND
856B E6 41          INC A3L+1
856D 68          INCEND PLA
856E B0 FF          BCS DMPEND
8570 38          SEC
8571 E9 01          SBC #801
8573 10 D2          BPL GETNXT
8575 60          DMPEND RTS

```

```

*
* Catalog list routine
*

```

```

8576 20 B1 00          CTLG  JSR CHRGET
8579 F0 05          BEQ DEFDRV
857B C9 31          CMP #831
857D F0 FE          BEQ PUTDRV
857F C9 32          CMP #832
8581 D0 14          BNE SNTX1
8583 8D 68 AA          PUTDRV STA $AA68
8586 AD 34 AE          DEFDRV LDA $AE34
8589 85 1D          STA CATFLG
858B A9 60          LDA #860
858D 8D 34 AE          STA $AE34
8590 A9 06          LDA #06
8592 20 AA A2          JSR $A2AA
8595 A5 1D          LDA CATFLG
8597 8D 34 AE          STA $AE34
859A 4C 2F 82          JMP ENDLST
859D 4C C9 DE          SNTX1 JMP SYNERR

```

```

*
* Screen messages follow
*

```

```

85A0 8D 8D          TOOLNG HEX 8D8D
85A2 D0 D2 CF          ASC "PROGRAM TOO LONG
                        TO FIT IN BUFFER."
85C4 8D 8D          HEX 8D8D
85C6 D0 D2 C5          ASC "PRESS <RETURN> TO
                        LIST, <ESC> TO EXIT"
85EB 00          HEX 00
*
85EC 8D 8D          ENDMSG HEX 8D8D
85EE A0 A0 A0          ASC " *** LISTING
                        COMPLETED ***"
860E 8D 00          HEX 8D00
END

```

# USEFUL FUNCTIONS

In last month's issue we printed the second of three programs that allowed you to easily access various defined functions. This saved aggravation and time when working with complicated mathematical formulas. We present, as a continuation of this, the third program which will put even more valuable formulas and functions at your fingertips. Again, we invite you to send in any defined functions you may be using that are not mentioned. The submissions we receive will be published in a future issue.

Save time and aggravation with a collection of defined functions.

→ Part 3 by Paul Garrison

```

1 REM FUNCTIONS (DELETE THOSE NOT USED IN A PROGRAM)
2 PI=3.14159
3 RAD=57.2958
4 DEF FNL(A,B)=-(A<=B)*A-(B<A)*B: REM LESSER OF A AND B
5 DEF FNG(A,B)=-(A>=B)*A-(B>A)*B: REM GREATER OF A AND B
6 DEF FNAV(A,B)=(A+B)/2:REM AVERAGE OF A AND B
7 DEF FNDX(A,X)=INT(A*X+.5)/X:REM LIMIT TO X DECIMALS
8 DEF FNRX(RHO,THETA)=RHO*SIN(THETA/RAD):REM P TO R, FINDS X
9 DEF FNPY(RHO,THETA)=RHO*COS(THETA/RAD):REM P TO R, FINDS Y
10 DEF FNRPR(X,Y)=SQR(X^2+Y^2):REM R TO P, FINDS RHO
11 DEF FNRPT(X,Y)=-(X=0 AND Y<0)*180-(X>0)*(90-RAD*ATN(Y/X))-(X<0)*(270-RAD*ATN(Y/X))
12 REM R TO P, FINDS THETA
13 DEF FNSSS(A,B,C)=RAD*2*ATN(SQR(((A+B+C)/2-A)*((A+B+C)/2-B)*((A+B+C)/2-C)/(A+B+C)))/((A+B+C)/2-A))
14 REM FINDS ANGLE OPPOSITE SIDE A,GIVEN 3 SIDES OF A TRIANGLE
15 DEF FNROOT(X,Z)=X^(1/Z):REM Z-ROOT OF X
35 DEF FNREC(A)=1/A:&REM RECIPROCAL OF A
36 DEF FNDEG(A)=A*(PI/180):REM DEGREES TO RADIANS
37 DEF FNRAD(A)=A/(PI/180):REM RADIANS TO DEGREES
38 DEF FNVOLC(S)=S^3:&REM VOLUME OF A CUBE
39 DEF FNVOLR(L,W,H)=L*W*H:REM VOLUME OF BOX
40 DEF FNVOLS(R)=4/3*PI*R^3:REM VOLUME OF A SPHERE
41 DEF FNVOLP(B,H)=B*H/3:REM VOLUME OF A PYRAMID
42 DEF FNVOLL(R,H)=PI*R^2*H:REM VOLUME OF A CYLINDER
43 DEF FNSURC(S)=6*(S*S): REM SURFACE OF A CUBE
44 DEF FNSURR(L,W,H)=2*(L*W)+2*(L*H)+2*(W*H): REM SURFACE OF A BOX
45 DEF FNSURS(R)=4*PI*R^2: REM SURFACE OF A SPHERE
46 DEF FNSURL(R,H)=2*PI*R^2+2*PI*R*H:REM SURFACE OF A CYLINDER

100 REM (PROGRAM TITLE, AUTHOR)
110 REM (TYPE OF BASIC USED)
120 GOTO 180
130 ?"_____":RETURN
140 HOME:VTAB(10):RETURN
150 ?:"Press > RETURN< (Q to quit)",R$

```

```

155 IF R$="Q" THEN 160 ELSE RETURN
160 GOSUB 140:GOSUB 130:?TAB(33)"End.":GOSUB 130:END
180 GOSUB 140:GOTO 2000
190 REM TESTING FUNCTIONS
200 ?"Find the lesser of two numbers":GOSUB 130
210 INPUT "Enter any two numbers",A,B
220 X=FNL(A,B):GOSUB 130
230 PRINT "The lesser number is";X:GOSUB 150:GOTO 2000
240 ?"Find the greater of two numbers":GOSUB 130
250 INPUT "Enter any two numbers",A,B
260 X=FNG(A,B):GOSUB 130
270 PRINT "The greater number is",X:GOSUB 150:GOTO 2000
280 ?"Find the average of two numbers":GOSUB 130
290 INPUT "Enter any two numbers",A,B
300 X=FNAV(A,B):GOSUB 130
310 PRINT "The average of the two numbers is",X:GOSUB 150:GOTO 2000
320 ?"Round number to X decimals":GOSUB 130
330 INPUT "Enter a number with many decimals",A
340 PRINT "Enter 10, 100, 1000 etc. to limit the number of decimals"
345 INPUT "to the number of zeros",LD
350 X=FNDX(A,LD):GOSUB 130
360 PRINT "The rounded-off number is ";X:GOSUB 150:GOTO 2000
370 ?"Polar to rectangular conversion, find X":GOSUB 130
380 INPUT "Diagonal length (rho)",RHO
390 INPUT "Angle to vertical line",THETA
400 X=FNPRX(RHO,THETA):GOSUB 130
410 PRINT "The horizontal length (X) is";X:GOSUB 150:GOTO 2000
420 ?"Polar to rectangular conversion, find Y":GOSUB 130
430 INPUT "Diagonal length (rho)",RHO
440 INPUT "Angle to vertical line (theta)",THETA
450 X=FNPRY(RHO,THETA):GOSUB 130
460 PRINT "The vertical length (Y) is";X:GOSUB 150:GOTO 2000
470 ?"Rectangular to polar conversion, find hypotenuse (rho)":GOSUB 130
480 INPUT "Horizontal length (X)",X
490 INPUT "Vertical length (Y)",Y
500 XX=FNRPR(X,Y):GOSUB 130
510 PRINT "The hypotenuse (rho) is";XX:GOSUB 150:GOTO 2000
520 ?"Rectangular to polar conversion, find angle (theta)":GOSUB 130
530 INPUT "Horizontal length (X)",X
540 INPUT "Vertical length (Y)",Y
550 XX=FNRPT(X,Y):GOSUB 130
560 PRINT "The angle (theta) is";XX:GOSUB 150:GOTO 2000
570 ?"Find the angle opposite side X using 3 sides of a triangle":GOSUB 130
580 INPUT "Horizontal length (X)",A
590 INPUT "Vertical length (Y)",B
600 INPUT "Diagonal length (hypotenuse)",C
610 X=FNSSS(A,B,C):GOSUB 130
620 PRINT "The angle opposite X is";X:Y=90-X
630 PRINT "The angle opposite Y is";Y:GOSUB 150:GOTO 2000
640 ?"Find the X root of a number":GOSUB 130
650 INPUT "Enter any number",X
660 INPUT "Enter root number",R
670 XX=FNROOT(X,R):GOSUB 130
680 PRINT "The ";R;" root of ";X;" is";XX:GOSUB 150:GOTO 2000
1450 ?"Find the reciprocal of a number":GOSUB 130
1460 INPUT "Enter any number",A
1470 X=FNREC(A):GOSUB 130
1480 PRINT "The reciprocal of ";A;" is";X:GOSUB 150:GOTO 2000
1490 ?"Convert degrees to radians":GOSUB 130
1500 INPUT "Enter number of degrees",A
1510 X=FNDEG(A):GOSUB 130
1520 PRINT A;" degrees equal ";X;" radians":GOSUB 150:GOTO 2000
1530 ?"Convert radians to degrees":GOSUB 130
1540 INPUT "Enter number of radians",A
1550 X=FNRAD(A):GOSUB 130
1560 ?A;" radians equal ";X;" degrees":GOSUB 150:GOTO 2000
1570 ?"Find the volume of a cube":GOSUB 130
1580 INPUT "Enter length of one side",A
1590 X=FNVOLC(A):GOSUB 130
1600 PRINT "The volume of the cube is ";X;" cubic measures":GOSUB 150:GOTO 2000

```

```

1610 ?"Find the volume of a rectangular box":GOSUB 130
1620 INPUT "Enter width of box",W
1630 INPUT "Enter length of box",L
1640 INPUT "Enter depth of box",H
1650 X=FNVOLR(W,L,H):GOSUB 130
1660 ?"The volume of the box is ";X;" cubic measures":GOSUB 150:GOTO 2000
1670 ?"Find the volume of a sphere":GOSUB 130
1680 INPUT "Enter the radius",R
1690 X=FNVOLS(R):GOSUB 130
1700 ?"The volume of the sphere is ";X;" cubic measures":GOSUB 150:GOTO 2000
1710 ?"Find the volume of a pyramid":GOSUB 130
1720 INPUT "Enter base area in square measures",B
1730 INPUT "Enter height of the pyramid",H
1740 X=FNVOLP(B,H):GOSUB 130
1750 ?"The volume of the pyramid is ";X;" cubic measures":GOSUB 150:GOTO 2000
1760 ?"Find the volume of a cylinder":GOSUB 130
1770 INPUT "Enter radius",R
1780 INPUT "Enter length of the cylinder",H
1790 X=FNVOLL(R,H):GOSUB 130
1800 ?"The volume of the cylinder is ";X;" cubic measures":GOSUB 150:GOTO 2000
1810 ?"Find the surface area of a cube":GOSUB 130
1820 INPUT "Enter length of one side",S
1830 X=FNSURC(S):GOSUB 130
1840 ?"The surface area of the cube is ";X;" square measures":GOSUB 150:GOTO 2000
1850 ?"Find the surface area of a rectangular box":GOSUB 130
1860 INPUT "Enter the width of the box",W
1870 INPUT "Enter the length of the box",L
1880 INPUT "Enter the depth of the box",H
1890 X=FNSURR(W,L,H):GOSUB 130
1900 ?"The surface area of the box is ";X;" square measures":GOSUB 150:GOTO 2000
1910 ?"Find the surface area of a sphere":GOSUB 130
1920 INPUT "Enter the radius",R
1930 X=FNSURS(R):GOSUB 130
1940 ?"The surface area of the sphere is ";X;" square measures":GOSUB 150:GOTO 2000
1950 ?"Find the surface area of a cylinder":GOSUB 130
1960 INPUT "Enter the radius",R
1970 INPUT "Enter the length of the cylinder",H
1980 X=FNSURL(R,H):GOSUB 130
1990 ?"The surface area of the cylinder is ";X;" square measures":GOSUB 150:GOTO 2000
2000 GOSUB 140:"Menu:":GOSUB 130
2010 ?1,"Lesser of two numbers"
2020 ?2,"Greater of two numbers"
2030 ?3,"Average of two numbers"
2040 ?4,"Limit number of decimals"
2050 ?5,"Polar to rectangular, find horizontal length"
2060 ?6,"Polar to rectangular, find vertical length"
2070 ?7,"Rectangular to polar, find diagonal length"
2080 ?8,"Rectangular to polar, find angle"
2085 ?9,"Angles opposite two sides"
2090 ?10,"Root of a number"
2100 ?11,"Reciprocal numbers"
2110 ?12,"Convert degrees to radians":GOSUB 130
2111 ?"To choose one of the above, press > RETURN < "
2112 INPUT "To see other choices, press > Y < ",Z$
2113 IF Z$="Y" THEN 2120 ELSE GOSUB 130:GOTO 2230
2120 GOSUB 140:?13,"Convert radians to degrees"
2130 ?14,"Volume of a cube"
2140 ?15,"Volume of a rectangular box"
2150 ?16,"Volume of a sphere"
2160 ?17,"Volume of a pyramid"
2170 ?18,"Volume of a cylinder"
2180 ?19,"Surface area of a cube"
2190 ?20,"Surface area of a rectangular box"
2200 ?21,"Surface area of a sphere"
2210 ?22,"Surface area of a cylinder":GOSUB 130
2220 ?23,"Exit program":GOSUB 130
2230 INPUT "Which?",WHICH:GOSUB 140
2240 ON WHICH GOTO 200,240,280,320,370,420,470,520,570,640,1450,1490,1530,1570,
1610,1670,1710,1760,1810,1850,1910,1950,160

```

○ ○ ○

# Spread Sheets & Data Communications

○ ○ ○

by John Steiner

This month we will take a look at a newly released spread sheet program and also look at data communications for the Color Computer. Both of these applications are very popular among CoCo users, and they probably constitute most of my time on the computer.

## Spread Sheets

One of the most popular classes of software for the microcomputer is the spread sheet. These useful programs have sold more microcomputers than any other type of software because of their versatility and usefulness. The CoCo user was not to be left out.

The first program available was Spectaculator by Radio Shack, which has many of the features of a spread sheet, but is missing quite a few of the more useful ones. C.C. Calc came along, and the first true CoCo spread sheet was available. The program, written in BASIC, has a relatively small sheet size and slow calculation speed, but many of the unique spread sheet features are there. Elite Calc was introduced at the April '83 Rainbowfest, and became the CoCo users first full fledged machine language spread sheet program. Though Elite Calc has its flaws, until recently it has been the only full sized spread sheet available for standard CoCo's. (Flex users have Dynacalc available. Though I have never seen it operate, the ads convey that it is indeed a full power spread sheet program.)

[Editor's Note: We use Dynacalc all of the time at MICRO for a very wide range of functions. It works very well.]

## VIP Calc

Softlaw, Inc. [Formerly Nelson Software Systems] has finally released VIP Calc. It's been a long wait [I remember asking for it at their booth at the April '83 Rainbowfest], but it was worth it. The powerful program is modeled after the granddaddy of all spread sheet programs, Visicalc. CoCo users who also have access to Visicalc on other systems will have no trouble becoming accustomed to VIP Calc.

There are improvements upon the original Visicalc, including sorting and setting individual column widths. Minor modifications have been made to take advantage of the particular hardware and keyboard features of the CoCo, however, so there are some differences in the command structure from the original Visicalc. Up to 16 display windows can be set to compare information. A bank switching technique allows up to 33K of spread sheet in a 64K computer. Up to fifteen digit precision can be selected, and trig functions have been included. One of the most useful features is a LOCATE command that can search a sheet for a specified formula or text entry.

A unique marketing strategy by Softlaw has eliminated the tape to disk version upgrade problem. VIP Calc, and many of their other programs include both tape and disk versions of the software. The "Combo" packaging is a nice feature.

VIP Calc's screen display is high resolution and the user can select between 32, 51, 64 or 85 characters per line. This makes for the largest Calc screen display for the

CoCo yet. The nice display comes at a price, though. Choosing a high resolution display causes the loss of about eight thousand bytes of available spread sheet memory. In addition, it slows down the program because of the length of time it takes to write the screen display. An 8K display will take a lot longer to write than the standard 512 byte CoCo screen.

In fact, speed (or lack of it) is probably VIP Calc's major deficiency. After using Elite Calc, which is very fast in calculation and display, VIP Calc seems to move like a turtle. It is helpful to turn off the automatic calculation mode when you are doing data entry, then use the ! command to recalculate after the data are entered. If you choose the 32 character screen display, you will find that screen display update is much faster, as well. However, the speed problem is a relative thing and, if I had not run other spread sheet programs, I probably never would have made any comments about it. You get used to it.

One of the slowest spread sheet programs I have ever seen is MicroPro's Calc Star, which can take upwards of 45 seconds to recalculate a medium size sheet. I use Calc Star for much of my business work, however, and find that the recalculation time is not of any real significance. The other advantages of using Calc Star outweigh the speed problem. VIP Calc is nowhere near that slow in calculating and displaying data, and it is a lot more powerful. I may end up changing to VIP for my company work.

One other disadvantage of VIP Calc for 32K only users is that some features were left out to conserve memory. Locate, Edit and the high resolution graphics screens are not available to 32K systems. This should give you enough incentive to make the jump to modify your system to 64K. VIP Calc will not run in a 16K computer.

I really enjoy using a spread sheet program for creation of numeric and even text data files. So many things can be done easily on a spread sheet that would take hours of programming time if you were to try to write a BASIC program to do the same thing. If you haven't had the opportunity to look into what a spread sheet can do for you, check it out. You might find that it can be a help in your daily work. For more details, and a simple program to introduce you to spread sheets, check out issue number 67

of Micro, December 1983. That issue was devoted to the spread sheet, and includes "MicroCalc", a spread sheet program for the CoCo.

## CoCo Communications

The Color Computer makes a great Videotex terminal, as many people have already found out. Terminal software is inexpensive, and Modems are becoming much more reasonable in price. Two useful, yet inexpensive Modems that work well with the CoCo are the Mura MM-100, and the Anchor Automation Volksmodem. The Mura retails for \$99.95, while the Volksmodem retails for \$79.95. I have seen them both advertised for less in mail order ads.

The biggest problem is in configuring a cable that works with them. The CoCo has only four of the 25 standard RS-232 lines. The Mura modem has a 25 pin standard connector, while the Volksmodem has a five pin DIN connector.

When connecting these, or any modem for that matter, there are really only four required lines for an RS-232 port. They are TXD [transmit data], RCD [received data], GND [ground], and CD [carrier detect]. The CoCo RS-232 port contains all these lines and, to work with any modem, they must be connected properly to the same lines on the modem connector.

One concept that has caused confusion in the past is the connection of RCD and TXD. Many people would make the assumption that RCD on the modem should be connected to RCD on the computer, and TXD would be connected likewise.

The connections won't work that way, however, since modems are usually wired as data sets, and computers are wired as data terminals. The difference this causes makes sense, though, so connection is made by putting the RCD line on the modem to the TXD line on the terminal. Similarly, the TXD line on the modem goes to the RCD line on the terminal. All other lines connect directly from the modem to the terminal.

Computer communications is an interesting aspect of the microcomputing hobby, and is becoming more and more useful in the world of business. The Dakota Database Bulletin Board System that I have been running since July of 1983 is still going strong, and over 3700 calls have been made to the system since it has been on line.

Last month we added an upgraded software package, and the BBS is more sophisticated in its message handling, uploading and downloading of programs and files, and general system operation. If you have a modem package, give the Dakota Database a call at 701-281-0233. It is online 24 hours a day, except for occasional periods of updating, and contains several Color Computer programs that you may download at no charge. I'll be looking for your message on the BBS.

*And, farewell. MICRO has decided to discontinue microcomputer specific columns in favor of topic specific columns, so this is the last time CoCo Bits will appear. I wish to thank all of you who have responded to this column for your comments, advice and general support. You may see me again soon in MICRO with a column on Telecommunications.*

**MICRO**

## Report on TPUG Conference

A lot happened at the 3rd Annual Toronto PET Users Group Conference. Brad Templeton, author of the utility package POWER and the assembler PAL, demonstrated a program development system that won't let the user make a programming mistake. For instance, in Pascal if you decide to write a PROCEDURE, the system will automatically provide the ENDPROC statement and prompt you for variable declarations, parameter lists, and such. Jim Strasma, Editor of The Midnight Gazette and Contributing Editor for MICRO, spoke on what to look for, and what to avoid, in commercial software. He emphasized selecting where you buy a product and evaluating product warranties.

Featured at the Saturday night banquet were VIC-based "Randy" robots, "Uses for a Dead Computer" by Transactor Editor Karl Hildon, and reminisces from TPUG founders Jim Butterfield and Lyman Duggan.

## What About the 264?

Jim Butterfield and Jim Strasma had a lively discussion on the merits of Commodore's newly announced 264 Computer. As if on cue, someone showed up with a 264 — straight from Commodore Canada. Butterfield soon had it hooked up and running. Surprisingly, the 264 is even smaller than the C-64. It has arrow-shaped cursor control keys arranged in a diamond pattern. There are three differences obvious just from the power-up message. First, there are over 60K bytes available for BASIC. Second, the BASIC is version 3.5. Third, a message appeared that said: "SUPERSCRIPT on key 1". When Jim pressed function key 1, the word processor appeared instantly — a demonstration of the 264's built-in software capability. Another function key read and displayed the disk directory. The eight function keys can each be assigned with a simple statement.

The 264 uses a processor called the 1701. Contrary to what I said in a previous column, this is a member of the 6502 family and uses the same mnemonics. It still has only a 64K address space, but due to a more sophisticated architecture, is able to keep most of its operating system "floating."

The BASIC is more powerful, including convenient disk commands, graphics and sound statements [instead of POKEs], and structured programming statements. There is also a built-in, extended, machine-language monitor, and — first time for Commodore since the KIM — a reset button!

On the minus side, there is no numeric keypad, cassette capability is gone, the sound is primitive [compared to the C-64], and there are no sprites. There should be 80 columns for a "productivity" machine. There are 16 different colors in 8 different luminances.

Commodore's emphasis in marketing the 264 will be "productivity," and, it's true, this machine is a lot easier to operate. My work would definitely go faster. Having a structuring capability available on power-up is a real treat. Also, the built-in extended monitor and reset button can relieve a lot of frustration in assembly language program development.

Despite all the productivity-oriented features, the actual hardware is a little disappointing. This machine seems to be aimed somewhere in between the IBM/IBM Clone market and the low-end market. Butterfield, going along with the productivity emphasis, thinks there's a place for the 264, but Strasma thinks it may be a case of "too little, too late". Due to its limitations in graphics and sound, there may not be much recreational software for it. I suspect the C-64 will still be alive and well a year from now. It appears that the 264 will really be introduced, but certainly not while the C-64 is doing so well. It doesn't really compare with the C-64, but will people be able to tell? The pricing is still uncertain (\$500?), and there may be some changes before it comes out. A numeric keypad and 80-column word processing would sure help productivity!

### COMAL for the Commodore 64

I recently purchased a COMAL disk from the COMAL Users Group and did a little playing with the graphics commands. I had reviewed a previous version of COMAL for the PET and saw some promise there. It is a structured language, yet without the picky syntax requirements of Pascal. It has most BASIC commands, as well as REPEAT...UNTIL, WHILE...ENDWHILE, FOR...NEXT, IF...THEN...ELSE...ELIF...ENDIF, and a good CASE structure. Like BASIC, it is easy to program because you don't have to deal with an editor, compiler, and P-code interpreter to get your program to run. All you have to do is edit the program and RUN it. This is particularly important in a learning situation. There were problems with the PET version I saw, such as a "split" interpreter, and a few minor bugs. Also, since the PET had its ROMs hard-wired in, COMAL had to be loaded on top of BASIC, taking up most of the valuable RAM. When I began seeing ads for the C-64 version, my interest was rekindled. I knew the architecture of the C-64 would be better suited to a COMAL implementation.

COMAL has been around for quite a while, but it has received little attention in the U.S. In Europe it has a strong following. It is the official teaching language in Denmark, Ireland, Sweden, and Norway, and will be soon in other countries. It was designed by Borge Christensen as a combination of the "best of Pascal and BASIC." The C-64 version boasts a built-in turtle graphics system, so its promoters now add Logo to their "best of" list.

COMAL works much the same as BASIC, in that you can execute commands in the immediate mode, and you can test each procedure or function as you write it. However, it actually is a little more complicated. The system makes three passes through a program. Syntax errors are detected as you enter each line. Then, when you RUN the program, two more passes are made. It sounds complicated and time consuming, but overall COMAL averages out to about three times faster than BASIC. For string manipulations, COMAL is much faster than that. The string functions are simpler, but more powerful, than those of Microsoft BASIC. For instance, you can assign a substring — not allowed in BASIC.

The graphics commands are very convenient and they work on either hi-res or multicolor bit-map screens. There is very little required to set up a bit map screen since the system is designed to operate in bank 3, the \$C000 block

and the RAM under the I/O area and Kernal ROMs. All the memory manipulation is taken care of automatically. There's also a whole set of sprite commands, but these are designed to work with a bit map screen. I was able to get a few sprites to work in bank 0 with ROM characters. There doesn't seem to be any easy way to use programmed characters, although it is possible. Part of the problem is that there isn't any published memory map or other documentation of COMAL's inner workings, although these are in the works. Another problem is that there is less memory available for machine language programs. One promising feature is that position-independent routines can be programmed as strings, a technique popular with advanced Atari programmers.

At the TPUG Conference, I met Len Lindsay, who runs COMAL Users Group, U.S.A., Ltd. (5501 Groveland Terrace, Madison, WI 53716). The users group owns the copyright to the disk version and distributes copies for \$19.95. He does allow individuals to freely copy the system disk, as long as they don't make any changes and don't make any money off it. Even large users groups may distribute copies, but they must check first with Len. Len is the major proponent of COMAL in the US, and he has been with it since nearly the beginning. He was founder of *The PET Gazette* (the most successful of several newsletters and magazines that were combined to form **COMPUTE!**), and is working to get COMAL established as a major force in the U.S. With a little help from enthusiastic users and a computer company or two, COMAL will take over even faster.

Support for COMAL is growing. The COMAL Users Group publishes a regular newsletter called *COMAL Today* (\$15/year), and an applications tutorial book series *Captain COMAL* (\$19.95 with disk for each book). In addition, there is a reference book, the *COMAL Handbook* by Len Lindsay (\$18.95), and a number of books from European publishers. All of these, including the European books, are available from the COMAL Users Group, and many are available in computer and book stores.

### A Better COMAL — How long will Commodore sit on it?

There is a better COMAL, but it is not available. Commodore owns it, and is taking its time with producing it. The disk-based COMAL reviewed above only leaves you with 10K free for your program (equivalent to 16K in BASIC terms). The new, cartridge-based COMAL will leave over 30K free, as well as add many new features and commands. One feature I have heard described is a multi-level error-trapping system. Although I don't know for sure, there should be a little more flexibility added to graphics programming. Len Lindsay, and a few others, have seen this new version, and are very impressed.

Like other companies, Commodore has limited manufacturing facilities, and the ROM burners required to make cartridges are particularly in demand for things like hot-selling games. For Commodore, it's a matter of juggling priorities and demands. Look for the COMAL cartridge in late summer or fall. In the meantime, you can buy the disk version, and learn all about the language. It will take a while to exhaust the 10K limit. Then keep up the pressure on dealers, so they can keep pressure on Commodore. It might work!

# Subscribe to MICRO...

## Save 20% and we'll send you a BONUS GIFT with your subscription!

Receive a coupon good for  
one MicroDisk of your choice.  
A \$15.00 Value — FREE!

Each Disk contains a variety of programs  
from Micro, all entered and ready to run on  
your machine. Saves time, avoids errors.

This offer expires October 31, 1984

### Fill out the attached card and mail today!

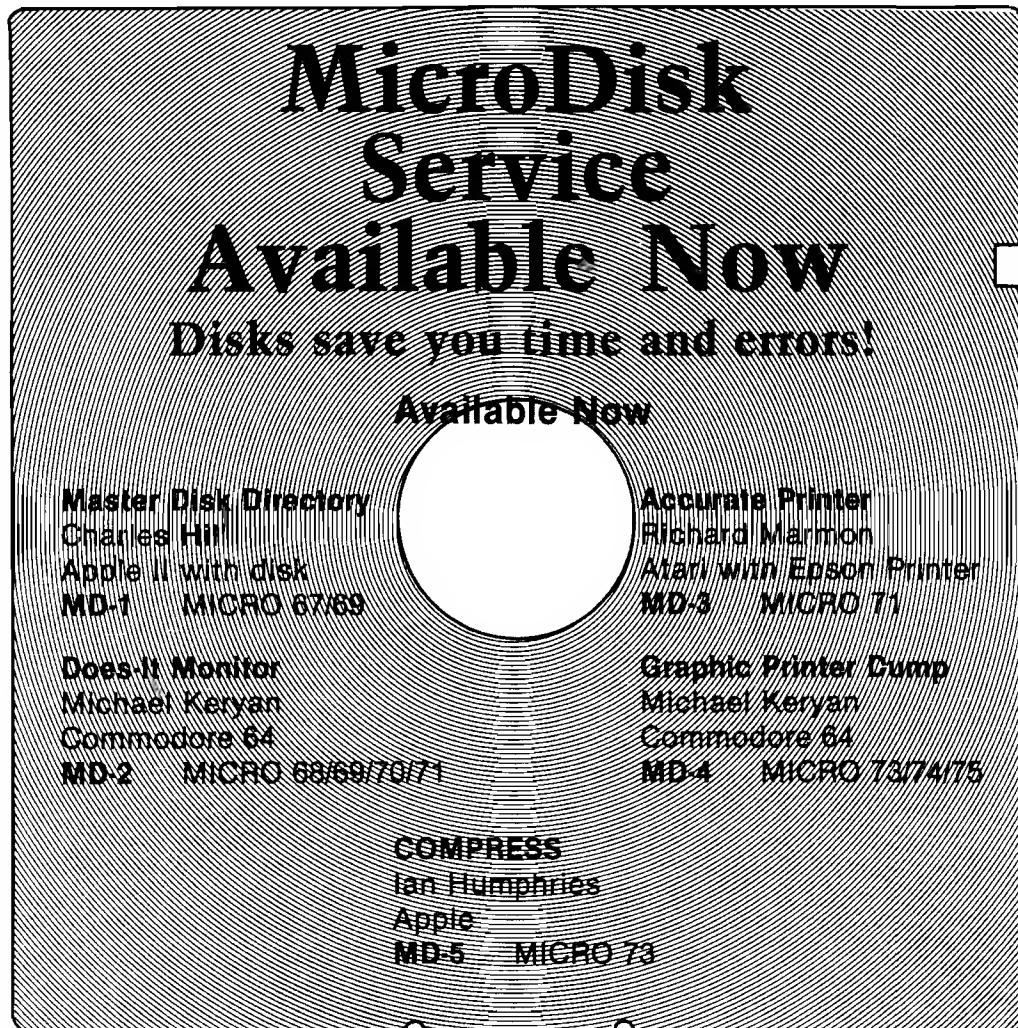
A graphic of a MicroDisk with a circular hole in the center. The text is arranged around the hole. At the top, it says "MicroDisk Service Available Now" in large, bold letters. Below that, it says "Disks save you time and errors!". Underneath, it says "Available Now" in a smaller font. There are five program listings arranged around the hole, each with a title, author, machine compatibility, and disk number. At the bottom, there is a listing for "COMPRESS" by Ian Humphries for Apple machines.

**MicroDisk  
Service  
Available Now**  
Disks save you time and errors!

Available Now

<b>Master Disk Directory</b> Charles Hill Apple II with disk MD-1 MICRO 67/69	<b>Accurate Printer</b> Richard Marmon Atari with Epson Printer MD-3 MICRO 71
<b>Does-It Monitor</b> Michael Keryan Commodore 64 MD-2 MICRO 68/69/70/71	<b>Graphic Printer Dump</b> Michael Keryan Commodore 64 MD-4 MICRO 73/74/75
<b>COMPRESS</b> Ian Humphries Apple MD-5 MICRO 73	

Each diskette includes all of the programs in BASIC and/or Assembly Source, plus binary 'load-and-go' files. The price of only \$15.00 includes shipping and handling.

**SAVE  
20%!**

**Use This  
Postage-Paid  
Card To  
Subscribe...**

**Or Call**

**617/256-3649**

**Expires Oct. 31, 1984**

*(MasterCard and VISA Accepted)*

**MICRO™**

**SAVE 20%**



**YES!** Enter my subscription to MICRO for just \$24.00 per year and send me a **BONUS GIFT COUPON** for one free MicroDisk.

Renew my subscription to MICRO for just \$24.00 and send me a **BONUS GIFT COUPON** for one free MicroDisk.

My mailing label number is MC\_\_\_\_\_

Name \_\_\_\_\_  
Address \_\_\_\_\_  
City \_\_\_\_\_ State \_\_\_\_\_ Zip \_\_\_\_\_

*(Allow 6-8 weeks for delivery)* Bonus Coupon offer expires Oct. 31, 1984

I'm paying by:  Check  MO  
 VISA  MC

Total Enclosed: \$ \_\_\_\_\_

Visa/MC # \_\_\_\_\_

Exp. Date: \_\_\_\_\_

## MICRO™'s Newest Software

### MicroDisks

Send me the following MicroDisks at \$15.00 each prepaid

- MD-1 Master Disk Directory
- MD-2 Does'It Monitor
- MD-3 Accurate Printer
- MD-4 Graphic Printer Dump
- MD-5 COMPRESS

### MicroCalc

#### The Full Screen Calculator

Easier than spreadsheet programs, does calculations of unlimited length and complexity on screen, links screens, saves on disk or tape, provides formatted printer output. Contains a 48 page manual and diskette.

- MicroCalc for Commodore 64.....\$29.95
- MicroCalc for Apple II/IIe/IIc.....\$29.95
- MicroCalc for Atari.....\$29.95

Please rush the Micro Software checked above to:

Name \_\_\_\_\_  
Address \_\_\_\_\_  
City \_\_\_\_\_ State \_\_\_\_\_ Zip \_\_\_\_\_

*MA residents add 5% sales tax.*

I'm paying by:  Check  MO  
 VISA  MC

Total Enclosed: \$ \_\_\_\_\_

Visa/MC # \_\_\_\_\_

Exp. Date: \_\_\_\_\_

## MICRO™'s Best Sellers

**We Pay All Shipping  
and Handling**

### Mastering Your Atari Through Eight BASIC Projects

Eight stimulating major projects on diskette — ready to entertain and educate you. Includes: Atari Player, Clock, MicroCalc, Word Detective, .... Fully described in 192 page book — the fun way to learn!  
 Mastering Your Atari \$19.95

### What's Where in the Apple

Revised new edition with Apple IIe information added to original atlas and gazetter. All Apple users will find this book helpful in understanding their machine and essential for mastering it.

- What's Where in the Apple 272 pages only ..... \$19.95

### Best Sellers for APPLE Users! MICRO on the APPLE

Programming aids, utilities, games, enhancements. Together Volumes 1, 2, and 3 contain over 100 programs on diskette. Fully documented and explained.

- 3-Volume Gift-Boxed @ \$59.95
- Vol.2  Vol.3 \$24.95 ea.

Please rush the MICRO Books I've checked above to:

Name \_\_\_\_\_  
Address \_\_\_\_\_  
City \_\_\_\_\_ State \_\_\_\_\_ Zip \_\_\_\_\_

*MA residents add 5% sales tax.*

I'm paying by:  Check  MO  
 VISA  MC

Total Enclosed: \$ \_\_\_\_\_

Visa/MC # \_\_\_\_\_

Exp. Date: \_\_\_\_\_



NO POSTAGE  
NECESSARY  
IF MAILED  
IN THE  
UNITED STATES

**BUSINESS REPLY CARD**  
FIRST CLASS PERMIT NO. 60, CHELMSFORD, MA

POSTAGE WILL BE PAID BY ADDRESSEE

**MICRO™**

P.O. Box 6502  
Chelmsford, MA 01824

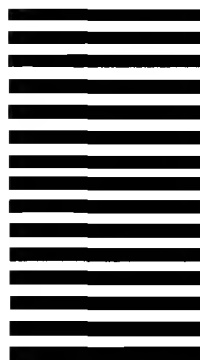

**SAVE  
20%!!!!**

**Subscribe  
to**

**MICRO**

Use This Postage  
Paid Card to Order  
the Next 12 Issues  
of MICRO and SAVI

**\$6.00 Off  
Newsstand Price!**

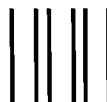

NO POSTAGE  
NECESSARY  
IF MAILED  
IN THE  
UNITED STATES

**BUSINESS REPLY CARD**  
FIRST CLASS PERMIT NO. 60, CHELMSFORD, MA

POSTAGE WILL BE PAID BY ADDRESSEE

**MICRO™**

P.O. Box 6502  
Chelmsford, MA 01824



**A Feast Of  
Computing  
Ideas...**

**New Book  
From**

**MICRO**



NO POSTAGE  
NECESSARY  
IF MAILED  
IN THE  
UNITED STATES

**BUSINESS REPLY CARD**  
FIRST CLASS PERMIT NO. 60, CHELMSFORD, MA

POSTAGE WILL BE PAID BY ADDRESSEE

**MICRO™**

P.O. Box 6502  
Chelmsford, MA 01824



**Order These**

**Best  
Sellers**

**From**

**MICRO**

# A Major Hardware Interface



by Ralph Tenney

Last time we began looking at the problem of connecting my 32K CoCo as a printer buffer for the 64K CoCo and my Commodore 64. A sketchy outline of the planned system was shown, and a simple RS-232 interface between a CoCo and the C-64 was shown. This month, let's do some detail designing of the major hardware interface — the receiver board for the 32K CoCo.

The most often overlooked item in hardware or software is a complete design specification. If you omit the spec while working for another person or company, two problems can arise. First, you may overlook a feature you verbally agreed to, and need a expensive re-design (at your expense). Second, the customer can say, "But I told you I wanted another printer port," or something similar. With an agreed-to and signed design specification, you have the opportunity to charge extra for changes made after the spec is signed off. In working for yourself, (always after a long day at work), it's easy to overlook something. If you have your own spec to work against, you can trade off bells and whistles against your own time and pocketbook if you decide to make a change. The point is that the project is under some control and won't "grow like Topsy" unless you decide to let it. Besides the other advantages, the design spec is an good start on the documentation you must have!

## Multi-Port COCO Interface

### I. Minimum Interface Capability

#### A. Centronics Compatible Parallel Ports

1. Port #1 must have a female Centronics style connector with pinout conforming to that of Figure 1. This port is an input and must accept a negative-going strobe pulse .5 uSec. wide (minimum) as a "data ready" signal and return a similar "acknowledge" pulse when ready to accept another data byte. An active-high "Busy" signal shall be provided in addition to the "data ready" and "acknowledge" signals. This port may be implemented as a cable terminating in the requisite connector.

2. Port #2 shall be output only, using a connector which can mate with the connector of Port #1. The pinout shall conform to that of Figure 1. This port must issue a negative-going "data ready" signal .5 uSec. (minimum)

1	STROBE* (DATA READY)
2	DATA1
3	DATA2
4	DATA3
5	DATA4
6	DATA5
7	DATA6
8	DATA7
9	DATAB
10	ACKNLG* (PRINTER READY)
11	BUSY
33	PRINTER GROUND
36	SLCT IN* (TIE TO GROUND TO SELECT PRINTER)

Figure 1

Figure 1. Pinout of Centronix-style parallel input plug.

wide and recognize a similar "acknowledge" pulse. The port shall also monitor a "printer busy" input and hold off further output until "busy" has gone inactive. This port must be implemented with cable of 15" minimum length.

#### B. RS-232 Serial Ports

1. Port #3 shall be an RS-232 input with selectable baud rates of 600, 1200 and 2400. An output line shall be provided for, with pinout to match the Radio Shack Color Computer serial port as implemented by the 1.1 BASIC ROM. A "busy" signal shall be returned on the fourth wire of the cable.

2. Port #4 shall be an RS-232 output only, with selectable baud rates of 600, 1200 and 2400. This channel shall have a unique output connector and be responsive to a "busy" input. The data normally assigned to the channel shall be capable of being diverted to the output of Port #3.

### II. Physical and Electrical Considerations

A. The interface card shall be physically compatible with the cartridge expansion port of the Radio Shack Color Computer and shall have external support provided for the end of the card opposite the connector. Cables used as input and output adapters shall be removable by plugging onto single- or double-row header strips.

B. The ports shall be based in the CoCo expansion I/O area between \$FF40 and \$FF7F and the controlling software must auto-start and be based at \$8000. A separate specification will define the functions of this software.

C. The two parallel ports shall be built with a 6522 VIA, plus a separate latch to generate the local "busy" signal and input logic to monitor the remote "busy" signal. A 6850 ACIA will be used for both ports with switch logic to divert the output channel as needed. An acceptable alternative is to create two full duplex channels with two ACIAs.

### Implementation of the Interface

Let's study the CoCo expansion port to see what we have to work with. Table 1 gives the pinout of this 40 pin connector. The application of most of the signals is obvious, but there are a few signals unique to the 6809/6883 architecture of the Color Computer. "E" is the

## BECOME A FAMOUS INTERNATIONAL AUTHOR !!!

What better place to start than MICRO, if you like:

- a fast turnaround on manuscript submissions
- being treated like a professional
- prompt payment at competitive rates
- national and international exposure (we have readers from Austria to Australia)
- being part of a magazine that is well established...7 years and going strong

Don't wait -- send for your Writer's Guide today.

Send a S.A.S.E. to:

Mike Rowe  
Micro Ink  
P.O. Box 6502  
Chelmsford, MA 01824

### ATTENTION COMMODORE 64 OWNERS:

"Is **THE CLONE MACHINE** really dead?"

Yes, there comes a time when a product grows old and isn't the latest state of the art. Thank goodness we understand that here at Micro-W. Our all new version (known as **SUPER CLONE**) will surely prove that we are still number one in the back-up business. You'll still get the old reliable Clone Machine but we've added the following:

- 1) A fast clone copy (approx 14 minutes) that's simple to use
- 2) A Super Unguard utility that quickly handles errors 20 thru 29 (and you don't even have to disassemble your drive like some of our competitors suggest)
- 3) A new unique way to back-up formerly uncopyable software

Don't worry if you are a registered owner of our earlier version, we've got you on file and this upgrade will only cost you \$10 plus shipping and handling. Dealers, call us for stock balancing on old merchandise.

**STILL ONLY \$49.95\***



Should've made back-ups with Super Clone

Available from  
**MICRO-W**  
DISTRIBUTING, INC.

1342B Route 23  
Butler, N.J. 07405  
CALL: (201) 838-9027 To Order  
Dealer and Distributor Inquiries Invited

\* We will allow \$15 trade credit for any other copy program that you have purchased toward the purchase of **SUPER CLONE** at \$49.95. You must provide your original purchased product and state why you want ours instead. This offer may be withdrawn at any time.

primary clock signal for the 6809, and Q is similar to the Phase 2 6502 clock, except that it is a quadrature clock which gives extended timing margins for interfacing. CTS\* is the main SELECT signal for the cartridge port, and is active for the the range \$C000 to \$EF00. SCS\* is a secondary SELECT strobe active between \$FF40 and \$FFC0 and is intended to select I/O devices. SLENB\* is furnished to entirely disable the internal decoding, which allows plug-ins such as the Z-80 module which runs C/PM software. HALT\* stops the 6809 and CART\* is the line which allows game cartridges to auto-start. (A second auto-start mechanism is available under Extended BASIC — if the bytes at \$C000 and \$C001 are "DK", control is handed over to the cartridge.) It is important to note that none of the processor address or data lines are buffered. The E and Q lines are generated by the bipolar 6883 and the two SELECT lines are generated by a low power Schottky IC. So, after choosing which IC is needed in the interface, we will need to examine the bus loading to be sure that the interface will not overload the computer.

TABLE 1 — CoCo Expansion Port

Pin	Function	Pin	Function
1	-12 Volts	21	Address A2
2	+12 Volts	22	Address A3
3	HALT*	23	Address A4
4	NMI*	24	Address A5
5	RESET*	25	Address A6
6	E {clock}	26	Address A7
7	Q {clock}	27	Address A8
8	CART	28	Address A9
9	+5 Volts	29	Address A10
10	Data D0	30	Address A11
11	Data D1	31	Address A12
12	Data D2	32	CTS* {SELECT 1}
13	Data D3	33	Ground
14	Data D4	34	Ground
15	Data D5	35	Sound input
16	Data D6	36	SCS* {SELECT 2}
17	Data D7	37	Address A13
18	R/W*	38	Address A14
19	Address A0	39	Address A14
20	Address A1	40	SLENB*

The interface board needs the following capability in addition to the specified I/O ports:

1. A clock source to generate the clock frequencies needed for the three specified baud rates
2. Decoding for the VIA, one or two ACIAs and at least one latch.

The ACIA (Asynchronous Communications Interface Adapter) uses one of two clock frequencies: 16 x the baud rate (/16 mode) and 64 x the baud rate (/64 mode). If you accept the software overhead required to change the ACIA divide ratio, the ACIA can be operated in both /16 and /64 modes with two input frequencies and gain one additional baud rate:

- 38400 Hz./16 = 2400 baud
- 38400 Hz./64 = 600 baud
- 19200 Hz./16 = 1200 baud
- 19200 Hz./64 = 300 baud

Figure 2 shows how these clock frequencies will be generated. The CD4024 is a 7-bit binary counter, and the CD4068 is an 8-input AND/NAND gate used to decode the counter output lines. The clock input to the counter is

**Figure 2**

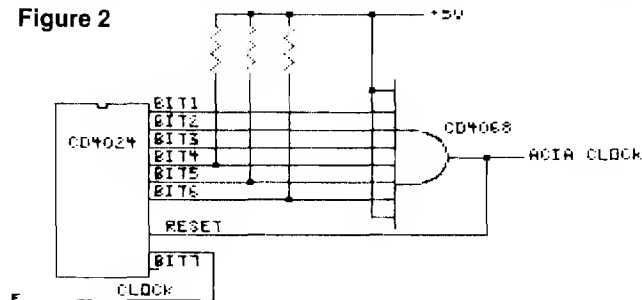

Figure 2. Counter and switched decoder circuit generates baud rate clock signals.

the 6809 "E" clock which runs at 895 kHz. Table 2 shows which counter outputs need to be decoded to generate the two frequencies. Note that three outputs are common between the two decoding schemes, so three counter outputs need to be selected or deselected to program the counter.

**TABLE 2 — Counter Coding**

- 895 kHz/23 = approx. 38400 Hz
- 895 kHz/46 = approx. 19200 Hz

- 23 = \$17 = 00010 111
- 46 = \$2F = 00101 111

Decode bits 0, 1 and 2 are common;  
Bits 3, 4 and 5 must be switched to select frequency.

### ACIA and VIA Decoding

Table 3 shows the decoding requirements for the 6522 VIA and the 6850 ACIA. The ACIA occupies only two memory locations and the VIA occupies 16 memory locations. You read the chart this way: CS (Chip Select) lines are shown true for a selected chip; any change will deselect the chip. An active-low CS line is typically driven by the decoder, while others are permanently selected or driven by a higher-order address line. RS lines work together to select individual registers, and are usually driven by low-order address lines. The ACIA uses the RS and R/W\* lines together to cram four registers into two address bytes. The price is that each register is read-only or write-only, which complicates the programming as will be discussed later.

**TABLE 3 — I/O Address Decoding**

6850 ACIA						
Register	RS	R- /W*	CS0	CS1	CS2*	
Control Reg	0	0	1	1	0	
Status Reg	0	1	1	1	0	
Transmit Reg	1	0	1	1	0	
Receive Reg	1	1	1	1	0	

6522 VIA						
Register	CS1	CS2*	RS3	RS2	RS1	RS0
I/O Reg B	1	0	0	0	0	0
I/O Reg A	1	0	0	0	0	1
DD Reg B	1	0	0	0	1	0
DD Reg A	1	0	0	0	1	1
Counter 1 Lo	1	0	0	1	0	0
Counter 1 Hi	1	0	0	1	0	1
Ctrl Latch Lo 1	0	0	1	1	0	
Ctrl Latch H1 1	0	0	1	1	1	
Counter 2 Lo	1	0	1	0	0	0
Counter Hi	1	0	1	0	0	1
Shift Reg	1	0	1	0	1	0
Aux Ctl Reg	1	0	1	0	1	1
Per Ctl Reg	1	0	1	1	0	0
Int Flg Reg	1	0	1	1	0	1
Int Ena Reg	1	1	1	1	0	
I/O A/NH	1	0	1	1	1	1S1

Figure 3 shows a 74LS138 decoder with the required connections to create memory "slots" for a number of I/O devices, and defines the memory locations for the VIA, ACIAs and a latch to be used on the interface. The 74LS138 is a three-line to eight-line decoder which has one active-high SELECT line (G1) and two active-low SELECT lines (G2A and G2B). If all the SELECT lines are true, the output addressed by the binary values on the three input lines (A, B and C) is active-low; all others are inactive. If any of the SELECT lines are false, all outputs are inactive. The primary SELECT is SCS\*, which must be low (G2A). By requiring Bit 7 to be low (G2B), the decoder is inactive above \$FF7F. With Bit 6 driving G1 and C, only the outputs 4, 5, 6 and 7 will be active. The selected devices and the effective addresses are shown in Figure 3. Note that the VIA entirely fills its assigned slot, but that the other devices will respond multiple times in their own slots.

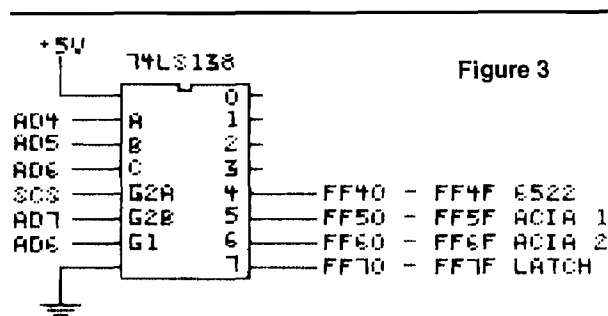

Figure 3. 74LS138 decoder circuit with resulting memory blocks and assigned function.



**Title: Overcoming Computer Illiteracy**  
**Authors: Susan Curran and Ray Curnow**  
**Price: \$12.95**  
**Publisher: Viking Penguin Inc.**

Written for those who have no previous knowledge of computers, this is Penguin's first foray into computer-related books. It is divided into five sections: Aspects of Modern Computer Technology, Manipulating Symbols, Development of the Computer — An Historical Perspective, Programming and Languages, Applications of Larger-Scale Computer Systems. The style of the writing is narrative, with no requirement of previous knowledge of computers, mathematics, or electronics. Simple programs are provided that can be used by beginners. The basic principles of data storage and manipulation are explained. The 6502 chip is chosen as an example for discussing the basic components and workings of microprocessor chips. Languages examined include machine language, BASIC, FORTRAN, COBOL and other high-level languages. Computer aided design, artificial intelligence, meteorological uses are among the applications discussed. A glossary and bibliography are provided. Points are illustrated through drawings, charts and tables.

Level: Beginner.

---

**Title: Introducing the Acorn/BBC Micro**  
**Author: Ian Sinclair**  
**Price: \$12.95**  
**Publisher: Prentice-Hall, Inc.**

Mr. Sinclair draws upon his many years of experience as a teacher and author in writing this introduction to the Acorn. As stated by the author, the Acorn was designed to a very advanced specification. Bearing this in mind he set to teach a beginner on a machine not well suited to beginners. The book is aimed at this level and makes no pretenses otherwise. Starting with instructions on how to set up your new Acorn, everything from tuning your TV to dealing with cables is dealt with. The programming concentrates on BASIC, neglecting those commands that might be common to other micros but are not part of the Acorn. The fundamentals of sound, graphics and color are shown, omitting those details that are too technical to be of use to a beginner. This approach of avoiding overly technical and lengthy discussions carries throughout the book. The examples are short and concise, saving the beginner from unnecessary confusion. The appendices cover Reserved Words, Cassette Capers, Appending Programs, Magazines and User Groups, and the Cassette Bug Fix. The latter is aimed at correcting a bug present in the 0.1 system's cassette. The book and programs are useful for both the 0.1 and the newer 1.2 operating system.

Level: Beginner.

**Title: 8-Bit & 16-Bit Microprocessor Cookbook**  
**Author: Joseph J. Carr**  
**Price: \$13.50**  
**Publisher: Tab Books, Inc.**

A reference and sourcebook that guides the reader in the technical realm of microprocessors. Offering much valuable information that is not easily found elsewhere, a variety of topics are covered: architecture, individual chip characteristics, handling of interrupts, timing, control signals, interfacing memory, pinouts, variations, interfacing I/O and the instruction sets. Of the different 8 and 16-bit microprocessors examined, the Z80 and 6502 are given particular attention and detail. Other 8-bit chips covered are Motorola's 6809 and 6800 and Intel's 8080A, 8085A, 8086, and 8088. The two 16-bit microprocessors that are given the most attention are the MC68000, Motorola's bid for the 16-bit market, and Intel's iAPX86/10. The appendices look at address decoder circuits and techniques, generating device-select pulses, input/output devices, and low-voltage DC power supplies. Certainly this field is too vast for this book to be comprehensive, but it definitely provides the reader with enough information to become knowledgeable about these more popular microprocessors.

Level: Intermediate to advanced.

---

**Title: The Anatomy of the Commodore**  
**Authors: Michael Angerhausen, Dr. Achim Becker, Lothar Englisch and Klaus Gerits**  
**Price: \$19.95**  
**Publisher: Abacus Software**

Starting with machine language programming, this look at the C64 as an all-around computer is a valuable guide. It begins with the Monitor and its uses, naturally progressing into the in's and out's of machine language programming. Then assembler programming is discussed, with a table of 6510 commands. Next, a more in-depth look is taken into memory configurations, the expansion and user ports and other special features of the 6510 microprocessor. Sound and graphics programming are covered, examining the Sound Controller 6581 and the Video Interface Chip 6567. The Analog/Digital Converter is explained, along with how to handle it. Sprite graphics are discussed in some detail, including capabilities, structure, and programming. The BASIC interpreter is viewed from a number of vantage points. A comparison table of Vic-20, C64 and CBM/PET ROM addresses is provided. The last chapter deals with input/output control — CIA 6526. The appendices consist of a ROM listing, a short lesson in Hexadecimal arithmetic, a summary of capabilities and a bibliography.

Level: Advanced beginner to Advanced.

**Name: Enstat Printer Mat**

Description: Dissipates static and absorbs sound and vibration from printers, electronic typewriters, etc. This single layer mat's positive static drain to ground functions in all temperatures and humidity conditions found in office or home environment and works with people and other conductive objects as well as machines. Sized to fit most tabletop equipment (18" x 22"), it has a 10 ft. ground cord with one megohm resistor.

A "bottom feed" design allows printer paper to pass over the mat edge, discharging static before it enters the printer.

Price: \$44.95

Available: Semtronics  
P.O. Box 599  
Scotch Plains, NJ 07076  
201/561-9520



**Name: McMill**  
**System: Apple II, II+, IIe**

Description: This 68000 coprocessor card is an excellent entry level educational board for those interested in working the 68000. It uses Motorola's 60008 processor which is totally code compatible with 68000.

Included are complete hardware documentation, schemata, and a FIG FORTH software. Optional software includes a 68000 cross assembler from SC Software which includes efficient debugging of code with simple trap monitor and built-in line oriented editor, and an enhanced screen editor for faster programming. McMill comes with a one-year hardware warranty.

Price: \$229 (\$299 with Assembler)

Available: Stellation Two  
P.O. Box 2342  
Santa Barbara, CA 93120  
805/966-1140

**Name: Flexible Head Cleaning Disk**

Hardware: 8", 5 1/4", or 3 1/2" drive

Description: A floppy disk head cleaner that dry cleans without abrasives and requires no liquid solution which might leave residue. Removes Ferric Oxide contamination and traps debris internally in special pockets. Just insert into drive and run for 30-60 seconds weekly. Each Disk provides 30 cleanings at about \$.83 per cleaning. Available in three sizes.

Price: \$24.95 (5 1/4" disk)

Available: Vikor Company  
P.O. Box 3123  
Nashua, NH 03061  
603/889-8530



**Name: PaperClip**  
**System: Commodore 64**

Description: This word processor allows a switch to 80-column display with no additional hardware, just a simple common routine. Horizontal scrolling up to 250 columns across for wider documents or tables also is possible. A powerful search capability uses unusually precise definition of "search" words. A unique printer set-up routine allows the user to get the best advantage of any printer, and support files include over 100 popular printers.

PaperClip also can be used with SpellPack, a spelling checker program with an internal dictionary of over 20,000 words.

Price: \$89.95

Available: Batteries Included  
3303 Harbor Blvd, Ste C9  
Costa Mesa, CA 92626  
714/979-0920

Name: **Bank President**  
System: Apple II, IIe, IIc,  
Macintosh, IBM

Description: This first title in a series is designed to teach the fundamentals of business strategy and decision making through role-playing games. As CEO, the player formulates strategy and makes decisions that determine how well the company performs. Users can play the game alone, against the computer, or in competition with other players. Actions of one competitor can affect the performance of another, as in real life. Players are CEO of a large commercial bank of any type they want, setting loan and deposit interest rates, raising or lowering employee salaries, investing capital and opening branches. Over 70 charts and graphs keep the player informed of the economy, bank conditions and competitors' actions. There are three levels of play.

High-Tech Entrepreneur and Venture Capitalist are the next two titles due in the series.

Price: \$74.95  
Available: Lewis Lee Corp.  
P.O. Box 51831  
Palo Alto, CA 94303  
415/853-1220

Name: **Simulated Computer**  
System: Atari, Commodore 64

Description: An award-winning simulation of the inner workings of a computer. The program takes you on a trip through an imaginary computer, revealing the secrets of machine and assembly language programming. You create a program and then see and hear the flow of data as it travels into memory, as registers are modified, and as the CPU processes information. The package has programmable sound and a graphics "turtle screen."

Price: \$  
Available: EduSoft  
P.O. Box 2560  
Berkeley, CA 94702  
1-800-EDUSOFT

Name: **Flying Colors**  
System: Commodore 64 (also  
Apple IIe/II+ versions)  
Hardware: Joystick

Description: A color graphics software package designed for use with a standard joystick. A windowed screen menu lets the user pick the desired functions for drawing. Choices include thick and thin lines, automatic circles and boxes of any size, erasures, and ability to fill enclosed areas with a variety of colors. Drawing speed can be adjusted for exacting detail work and different colors and brush sizes are available for painting. Text can be added anywhere to the screen and a grid helps align the pictures. Pictures can be saved and retrieved from disk.

A sophisticated Slide Projector program is also included so users can create their own slide shows for business presentations and recreation.

Price: \$39.95  
Available: The Computer  
Colorworks  
3030 Bridgeway  
Sausalito, CA 94965  
415/331-3022



Name: **Dimension 68000**  
Memory: 256K RAM (512K  
optional)  
Language: Virtually all

Description: This amazing machine comes with a display that handles up to 100 characters by 48 lines in 16 colors, and two 5 1/4" floppies, serial, parallel and game controller interfaces, and a six-slot internal expansion but that makes possible expansion to 12.5 megabytes of RAM and even more.

However, the most exciting part is that this computer can run almost any company or microprocessor's software. Plug-in CPU cards automatically reconfigure the disk drive format and video display to imitate the hardware of the simulated machine. CP/M-68K is standard, but p-System, Idris, UNIX are all possible, as are Apple, IBM, KayPro and other CP/M and MS-DOS software.

Price: Under \$4000  
Available: Micro Craft Corporation  
4747 Irving Blvd.,  
Suite 241  
Dallas, TX 75247  
214/630-2562

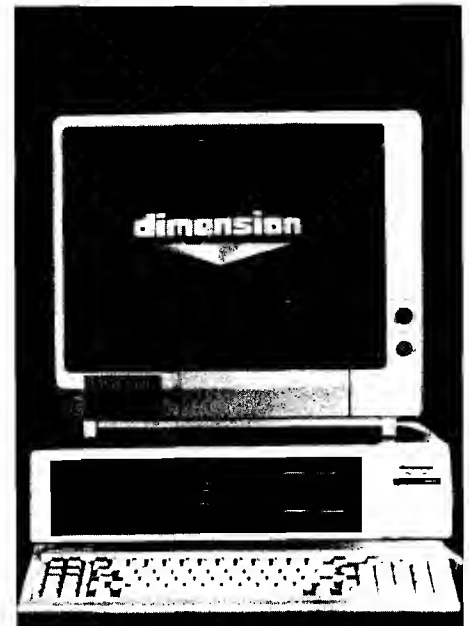

# byte bytes

by Mark S. Morano

## C R C O M P U T E R S S W O R D S

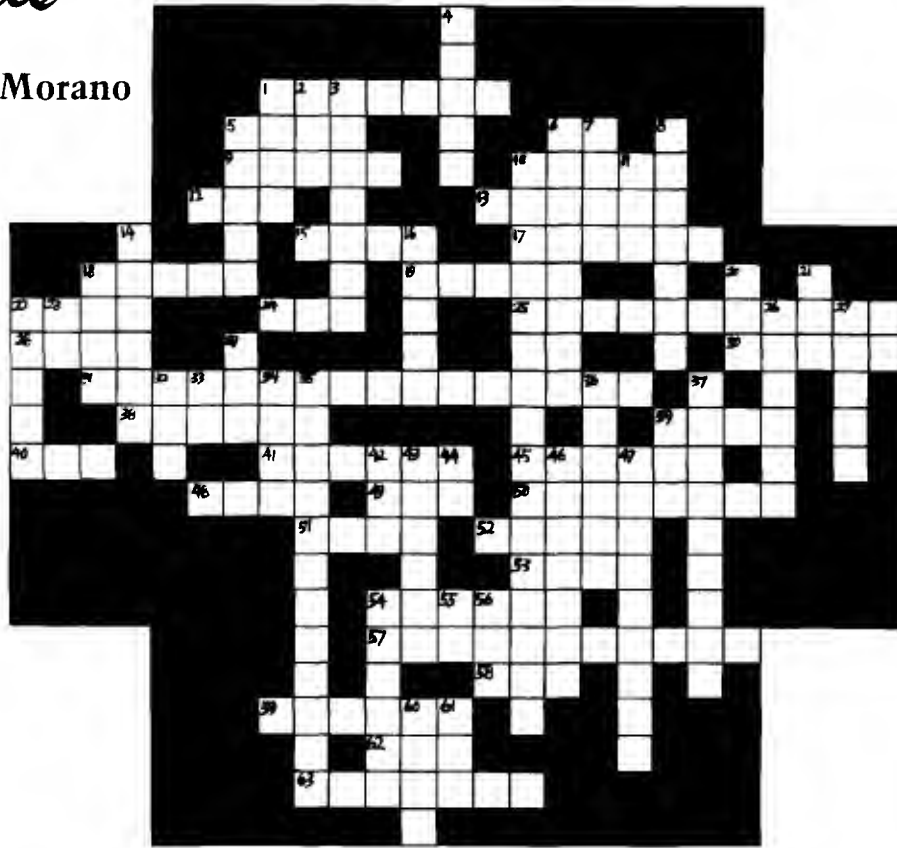

### ACROSS

1. A hackers ham.
5. It not less, than \_\_\_\_\_.
6. Strength of light given off by candles {abbr}.
9. To wipe out.
10. A printers favorite flower.
12. Branch on not equal {abbr}
13. \_\_\_\_\_ Bowes.
15. In heaven they are pearly {singular}.
17. A kind of graphics.
18. What tax evaders and programmers have in common.
19. Dot.
22. A \_\_\_\_\_ off the old block.
24. A feline.
25. The study of controlling an industrial process automatically by computer.
28. Composer with speech impediment, Franz \_\_\_\_\_.
30. Cold hard \_\_\_\_\_.
31. A dying impersonator
38. A kind of race that impulses play.
39. Don't touch the third one.
40. A shortened room.
41. A sign that sounds like a crash.
45. A chauffer.
48. If — \_\_\_\_\_ — else.
49. A TV by any other name.
50. You need to do this to vote.
51. Secret \_\_\_\_\_.
52. Photo color with brownish tint.
53. Transported with delight.
54. What the Apple programmer exclaimed when he found out his assembler was missing.
57. What Bob Hope's annual performance rate has dropped to.
58. Minus without the vowels.
59. A description of space games.
62. What a programmer puts on when his program bombs.
63. A bust builder.

### DOWN

1. What is leftover after eating an apple.
2. What holds a woman in place.
3. To begin again.
4. One of the 3 R's.
5. An orderform for restaurants.
6. What an instigator is.
7. Needles and \_\_\_\_\_.
8. 'The books must be done \_\_\_\_\_ end or else!'
10. What a mail clerk does best.
11. Ready, \_\_\_\_\_, go!
14. Our Lady of Grace.
16. A dance for those who change their mind.
18. What Santa checks twice.
20. A manufacturer that sounds like the floor of a ship.
21. What nervous programmers develop.
22. On a \_\_\_\_\_ day.
23. A greeting.
26. A suitor.
27. Both astrology and hit records have this in common.
29. A group of professional hide and sneakers.
32. Hi \_\_\_\_\_ {abbr}.
33. Machine Language {abbr}.
34. What crashes, rises and drops, {abbr}.
35. A form of communication using signals to start and stop.
36. Where something starts.
37. \_\_\_\_\_ coordinates.
39. Lo \_\_\_\_\_.
42. A coding scheme that sounds like a brand of underwear.
43. A state where apples grow.
44. Light {abbr}.
46. Over and over, again and again.
47. A way computers talk.
54. An unusual state of affairs.
55. Luxury Edition {abbr}.
56. Snow White {abbr}.
60. Internat'l Conference on Information Processing {abbr}.
61. Conditional Transfer of Control {abbr}.

# Advertiser's Index

Batteries Included	69
Computer Colorworks	70
Computer Mail Order	67
Computerose	Back Cvr
EduSoft	70
Hudson Digital Electronics	53
IQB Enterprises	35
Lewis Lee	70
MICRO	51,64,Ins Back Cvr
Micro Craft Corp	70
Micro-W Distributing	66
Midwest Micros	13
Nikrom Technical Products	8
Performance Micro	29
Protecto	22,23,24,25,26,27
Quantum Software	34
Schneider Systems	18
Semtronics	69
Skyles Electric Works	Ins Front Cvr
Specialty Electronics	14
Stellation Two	9,69
Such-A-Deal Software	50
Totl Software	3
Transactor	1
Vikor Co	69

# MICRO

## Solving Lyte Bytes

In the July issue, Lyte Bytes had a computer word puzzle which required unscrambling the words and then arranging letters to find the answer. Below is the proper solution.

*B E C A U S E / H E / L O S T / H I S / D R I V E .*

NCEMMUOIN	M N O U M O N O C
LXEPI	P O X E L
VICRSEURE	R E C U R S I V E
RPHEOP	H O P P E R
EDPCOUESOD	P S E O D O C O D E
GRMIOTLAH	A L G O R I T H M
CIKDOLRG	G R I D L O C K
CAUPDETIL	D U P L I C A T E
ITUNENOMLITOEMCAC	T E L E C O M M U N I C A T I O N
RIBYAN	B I N A R Y
ILECDHAMXIE	D E X I D E C I M A L
CBYISOML	S Y M B O L I C

# MICRO

## MICRO Reader Survey

The Editorial Staff and Advertising Staff of MICRO want to sincerely thank the hundreds of readers who have taken the time and made the effort to complete and return the **READER SURVEY** that was included in the June issue. We are currently working to encode and analyze the information that you provided. Although it will be a couple of weeks before the results are fully 'digested', this information has already started to influence our editorial directions and has been helpful in defining our readership to the advertising community.

If you have not yet returned your questionnaire, please do so before the end of August so that your interests will be represented.

## Coming in September —

As announced in previous editorials, MICRO is extending its coverage into some new areas, some of which are represented in the September issue by:

- An Introduction to FORTH, *by Kenneth Butterfield*  
The basic whys and wherefores of this language
  - A Structure Tree Utility in FORTH, *by Mike Dougherty*  
Produces "road-maps" of FORTH applications
  - Multi-Tasking in FORTH, *by Kenneth Butterfield*  
How to implement a Multi-Tasking system
  - 68000 Exception Processing — Part 1, *by Mike Rosing*  
Taking care of software and hardware 'exceptions'
- Our coverage of the 6502/6809 world continues with:
- Graphic Printer for C64 — Part 3, *by Michael Keryan*  
Add full color capabilities to your printer
  - Time Series Forecasting, *by Brian Flynn*  
Programs to forecast 'The Market', weather, ...

# What's Where in the APPLE

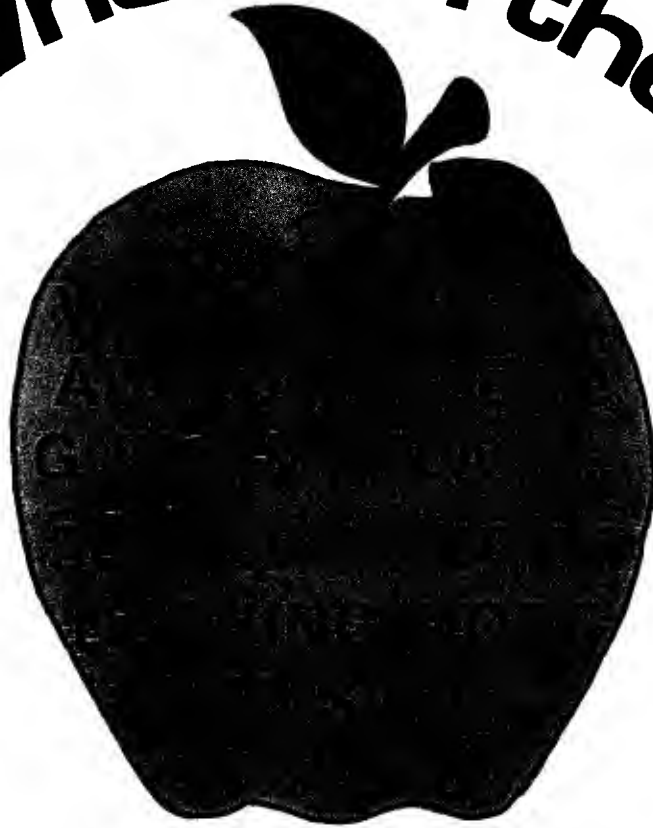

This famous book now contains the most comprehensive description of firmware and hardware ever published for *the whole Apple II family*. A new section with guide, atlas and gazeteer now provides Apple IIe specific information.

- Gives names and locations of various **Monitor**, **DOS**, **Integer BASIC** and **Applesoft** routines and tells what they're used for
- Lists **Peeks**, **Pokes** and **Calls** in over 2000 memory locations
- Allows easy movement between BASIC and Machine Language
- Explains how to use the information for easier, better, faster software writing

**This expanded edition is available at the new low price of only \$19.95**

For the 35,000 people who already own previous editions, the IIe Appendix is available separately for just \$5.00.

Please send me:

\_\_\_\_\_ What's Where in the Apple @ \$19.95 ea.  
(Plus \$2.00 per copy shipping/handling)

\_\_\_\_\_  
Name

\_\_\_\_\_ Apple IIe Appendix @ \$5.00 ea.  
(includes shipping charges)

\_\_\_\_\_  
Address

Mass residents add 5% sales tax \$ \_\_\_\_\_

City \_\_\_\_\_ State \_\_\_\_\_ Zip \_\_\_\_\_

Total Enclosed \$ \_\_\_\_\_

Signature \_\_\_\_\_

Check     VISA     MasterCard

For faster service  
Phone 617/256-3649

Acct # \_\_\_\_\_ Expires \_\_\_\_\_

MICRO, P.O. Box 8502, Chelmsford, MA 01624

Parental guidance suggested.



**Take an active role in your child's development.**

Parenting. The most important and rewarding endeavor you'll ever undertake. Gaze into your child's eyes. They're capturing all the wonders of the world around him, and looking to you for guidance.

Now you can gain a unique insight into your child's world with Childpace™ — an amazing new Child Development Program for ages 3 to 60 months.

**Share the precious firsts.**

When will your baby dazzle you with his first spontaneous smile? Stand alone? Take that first wobbly step?

The first five years are filled with continual growth and change. And questions. So even if your child's a toddler, you're still looking for answers. When will he start dressing himself? When should those random scribbles turn into distinctive shapes?

**Compare apples-to-apples.**

Childpace lets you evaluate your child's dexterity, language and social

skills in the privacy of your own home. You enter information into Childpace, then he attempts tasks that are appropriate for his age group.

Childpace assesses his skill level based on extensive research, not the biased opinions of friends or relatives. Childpace uses your child's chronological (actual) age.

**Grow with your child.**

As your child grows, the tasks change to match his newly acquired skills. So Childpace is just as valuable for a 48-month old child as for an infant. Childpace can even evaluate up to 16 different children, and keep permanent records on each of them. Snapshots record your child's physical growth, but Childpace documents his or her actual development.

Track your child's progress, and help him develop specific skills. Childpace also contains warning signals to alert you to potential developmental problems at an early age, before they hold your child back. An ounce of prevention pays off.

Childpace. A fascinating glimpse into the world of child development. And more importantly, into *your child's* world.

Look for Childpace at your local computer hardware or software store. If unable to find it, send \$39.95 to Computerose, Inc. Please allow two weeks for processing. 30 day money back guarantee.

**\$39.95** suggested retail price

Childpace is available for the Commodore 64®, IBM PC®, IBM PC Jr.®, Atari 800®, Apple II®, and Radio Shack Color Computer®\*

\*Each is a registered trademark of the respective manufacturer.

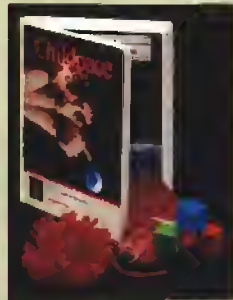

**Computerose**  
We're programming for life.™

2012 East Randol Mill Road Suite 223  
Arlington, TX 76011 (817) 277-9153  
© 1984 Computerose, Inc.